

Auros Series NEW MODEL

VER305, VER405, VER505, VER605

Auros series

RECUPERATOR FEATURES

- Mounting position – wall (wall batten included) and floor standing (VKNER legs sold separately)
- 360° rotating connection joints
- Counterflow heat exchanger with the efficiency of up to 95%
- Energy-efficient fans with the Ziehl-Abegg EC motors
- Automatic bypass, 100% bypass, isolated
- Modulating preheat coil with variable operating parameters
- Excellent insulation thanks to the use of the EPP (expanded polypropylene) housing
- Leak tight structure preventing the penetration of odours and pollutants from the exhaust air into the supply air
- Mobile application for smartphones – Android, iOS and possible remote control by using webpage (iNext module required)
- Automatic flow control system (constant flow) – in CF versions.
- Equipped with two filters (M5/ISO ePM10) as a standard
- Possibility of using fine filters (F7/ISO ePM1) with higher filtration class
- Possibility of using reusable pre-filter.
- Possible interoperation with the air quality, carbon dioxide and humidity sensor (VSPM, VSHC, VSHW)
- Option of cleaning heat exchanger
- Long service life
- Scratch resistance of painted parts at a value of 5 H
- Antimicrobial properties of painted parts according to ASTM E2149-13a



Supplementary products

LEGS
VKNER

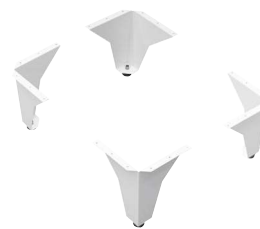

FILTERS
page 24



Auros Series

VER305, VER405, VER505, VER605

Auros series

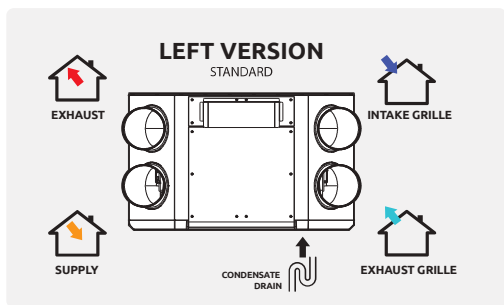

VER305L	Recuperator AUROS 305 left version (standard)
VER405L	Recuperator AUROS 405 left version (standard)
VER505L	Recuperator AUROS 505 left version (standard)
VER605L	Recuperator AUROS 605 left version (standard)
VER305LCF	Recuperator AUROS 305 left version (standard) + module CF
VER405LCF	Recuperator AUROS 405 left version (standard) + module CF
VER505LCF	Recuperator AUROS 505 left version (standard) + module CF
VER605LCF	Recuperator AUROS 605 left version (standard) + module CF

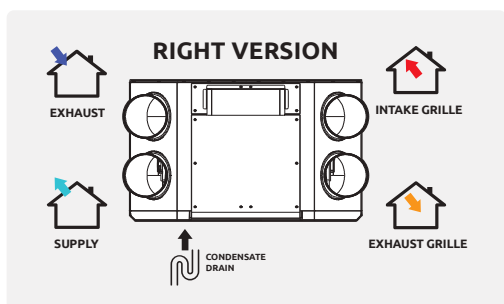

VER305P	Recuperator AUROS 305 right version (standard)
VER405P	Recuperator AUROS 405 right version (standard)
VER505P	Recuperator AUROS 505 right version (standard)
VER605P	Recuperator AUROS 605 right version (standard)
VER305PCF	Recuperator AUROS 305 right version (standard) + module CF
VER405PCF	Recuperator AUROS 405 right version (standard) + module CF
VER505PCF	Recuperator AUROS 505 right version (standard) + module CF
VER605PCF	Recuperator AUROS 605 right version (standard) + module CF

TECHNICAL INFORMATION

	SERIES300	SERIES400	SERIES500 NOVELTY	SERIES600
INDEX	VER305	VER405	VER505	VER605
Supply voltage	230 V AC / 50 Hz			
IP protection class	IP33			
Preheat coil power	2000 W			
Max. power consumption (without preheat coil)	195 W	280 W	295 W	340 W
Capacity (at 100 Pa)	313 m ³ /h	430 m ³ /h	508 m ³ /h	605 m ³ /h
Maximum engine speed	3 600 RPM	4 000 RPM	3 500 RPM	4 400 RPM
Noise level	44,0 dB(A)	44,3 dB(A)	44,0 dB(A)	45 dB(A)
Type of heat exchanger	RECAIR cross - counter - flow heat exchanger (optional enthalpy)			
Max. heat recovery efficiency	up to 95%			
Heat exchanger material	Polystyrene			
Housing material	EPP + powder coated steel			
Filter - intake vent	VM5ER405 - M5 ISO ePM10 VF7ER405 (optional F7 ISO ePM1)		VM5ER605 - M5 ISO ePM10 VF7ER605 - (optional F7 ISO ePM1)	
Filter - exhaust	VM5ER405 - M5 ISO ePM10		VM5ER605 - M5 ISO ePM10	
Pre-filter intake / exhaust	VFWER305 (optional)	VFWER405 (optional)	VFWER505 (optional)	VFWER605 (optional)
Diameter of air connector	160 / torsional	160 / torsional	200 / torsional	200 / torsional
Diameter of condensate drain connector	32 mm			
Controller type	AERO 4 + NANO COLOR (colored)			
Bypass	Automatic 100%			
Fans	2x radial fan with EC motor			
System Constant Flow	YES, depend on version			
Komunikacja Modbus RTU	YES			
Internet module	VLAN iNEXT (optional)			
Air quality sensor	VSPM (optional)			
CO ₂ concentration and humidity sensor	VSHC (optional)			
Humidity sensor	VSHW (optional)			
Weight	43 kg	46 kg	52 kg	

PRODUCT DATA SHEET

Auros Series

VER305, VER405, VER505, VER605

AUROS with horizontal mounting
on VKNER legs (sold separately)



DIMENSIONS

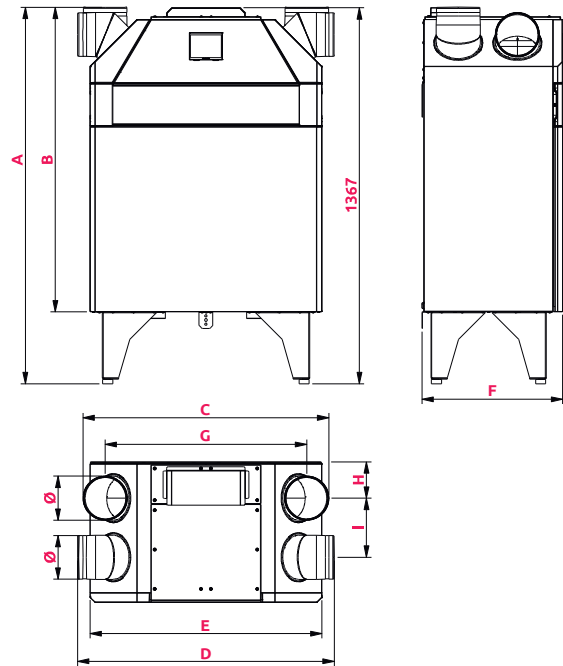

	Ø	A	B	C	D	E	F	G	H	I
VER305	160	1 370	1 108	764	804	713	510	604	132	215
VER405	160	1 370	1 108	894	934	843	510	743	132	215
VER505	200	1 377	1 115	946	962	843	610	748	147	265
VER605	200	1 377	1 115	946	962	843	610	748	147	265

DIMENSIONS

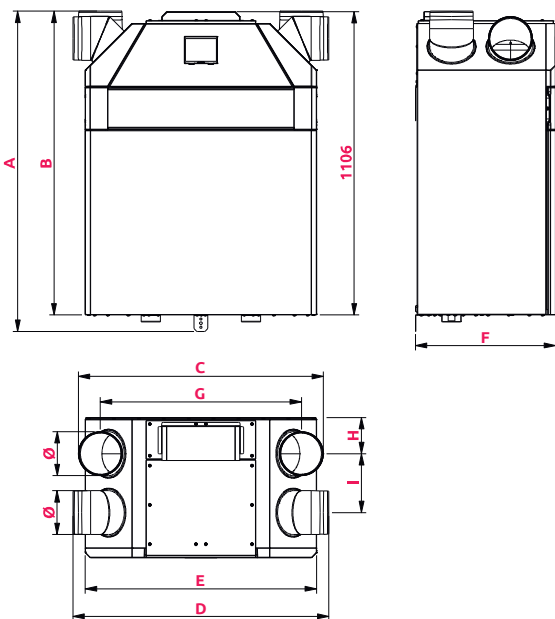

AUROS with wall-mounting on strip
(included in the scope of supply)





ENERGY EFFICIENCY



MATERIAL

Auros Series

VER305, VER405, VER505, VER605

CAPACITY



AUROS 305

VER305

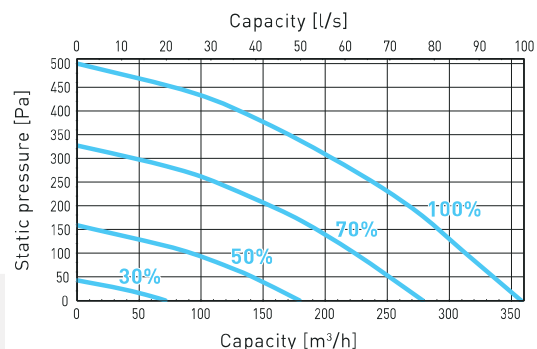

Auros 405

VER405

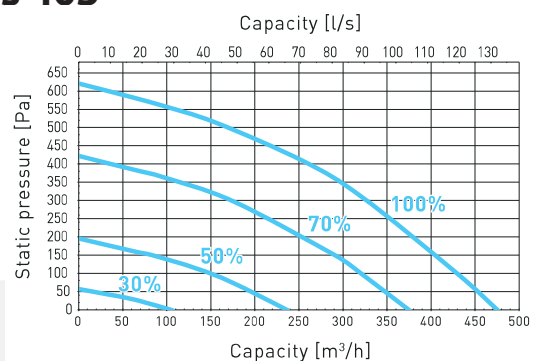

Auros 505

VER505

NOVELTY

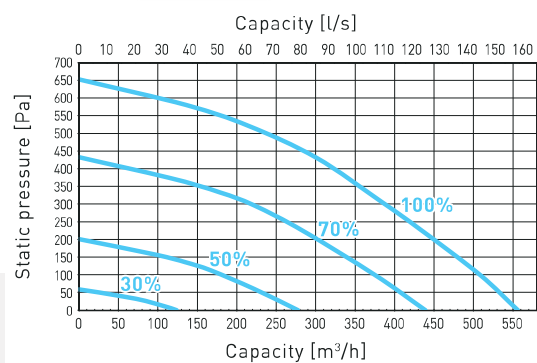

Auros 605

VER605

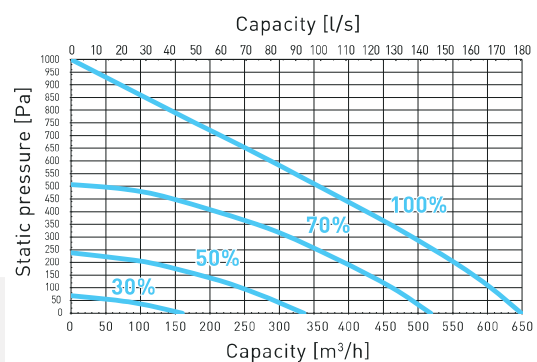

Auros series