

PRODUCT DATA SHEET

Distribution box with side connection

VCB160-14, VCB160-14/90

NOVELTY SYSTEM **Ø90**



TIGHTNESS CLASS



MATERIAL



BACTERIOSTATIC

The Awenta PRO VCB distribution box allows the connection of up to 14 Ø75-90 ventilation ducts.

As with the other distribution boxes in the VCB series, unused spigots can be covered with plugs with gaskets included with the product. The box is characterised by a side connection with a diameter of Ø160 mm.

Distribution boxes with side connections are ideal for installation above suspended ceilings and wherever installation height is limited.

The suitably profiled shape of the Awenta PRO boxes allows for a quiet air flow, while ensuring low pressure loss.

AWENTA PRO boxes are a well-thought-out design for long-term use. Thanks to their structure and the use of high-quality plastics and bacteriostatic additives, they will meet the expectations of the most demanding users.



VCB160-14

VCB160-14/90



AIR FLOW CHARACTERISTICS

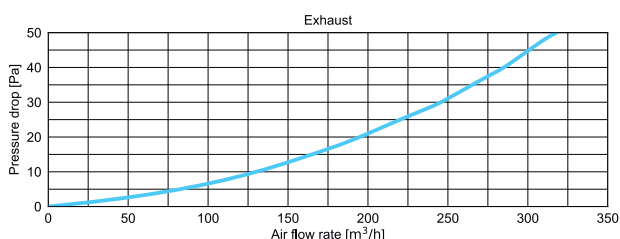
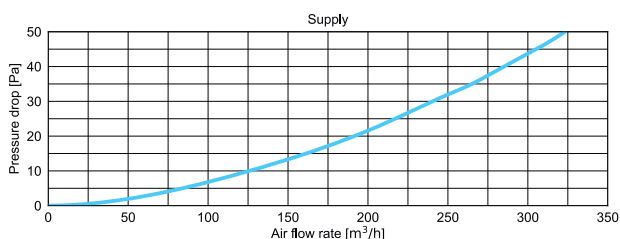
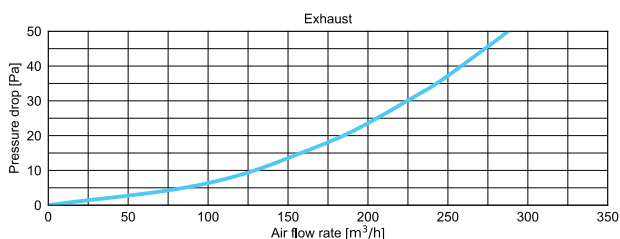
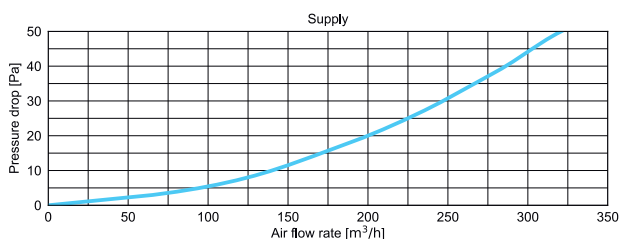

DIMENSIONS

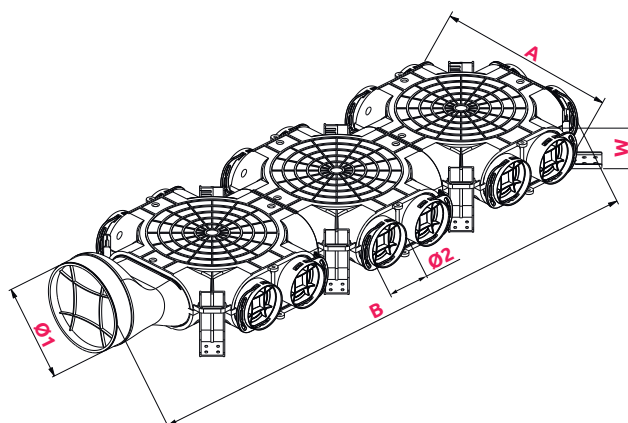

	Ø1	Ø2	A	B	W
VCB160-14	160	75	347	1057	104
VCB160-14/90	160	90	407	1086	104

WITH **NANOSILVER** ADDITIVE
ELIMINATING UP TO **99%** BACTERIA

