

PRODUCT DATA SHEET

Distribution box

VCB160-8, VCB200-8, VCB160-8/90, VCB200-8/90

NOVELTY SYSTEM Ø90

D
TIGHTNESS CLASS

PP
MATERIAL

BACTERIOSTATIC

The AWENTA PRO VCB distribution box is used for the distribution of supplied air or collection of used air from rooms connected to the heat recovery system and it is directly connected to the air handling unit.

AWENTA PRO distribution boxes are made of modified polypropylene with the Nano-Silver bacteriostatic additive. The robust structure is equipped with a system of gaskets guaranteeing tightness and failure-free operation for many years. The use of a bacteriostatic additive made it possible to obtain bacteriostatic activity at a very high level.

The VCB distribution boxes are available in different connection options allowing for the connection of up to 8 Ø75-90 mm ventilation ducts. All VCB boxes are supplied with mounting gaskets for a tight connection between the female connector and the ventilation duct. An integral part of each box is its mounting system, for which special adjustable mounting brackets are used.



VCB160-8

VCB160-8/90



AIR FLOW CHARACTERISTICS

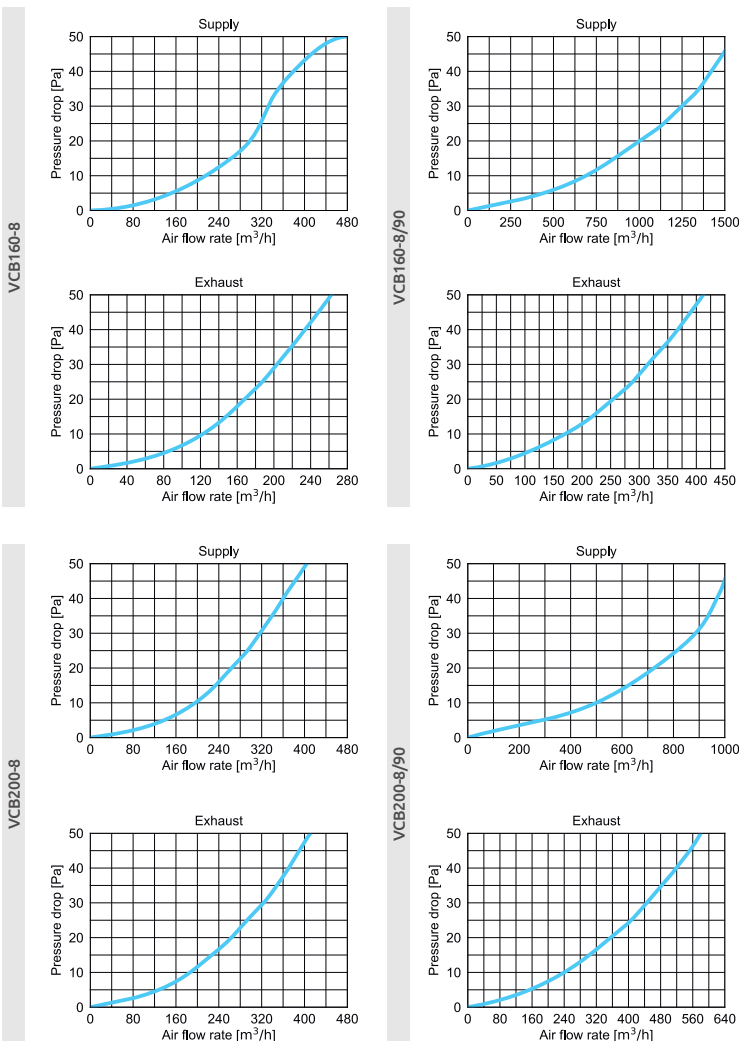

DIMENSION

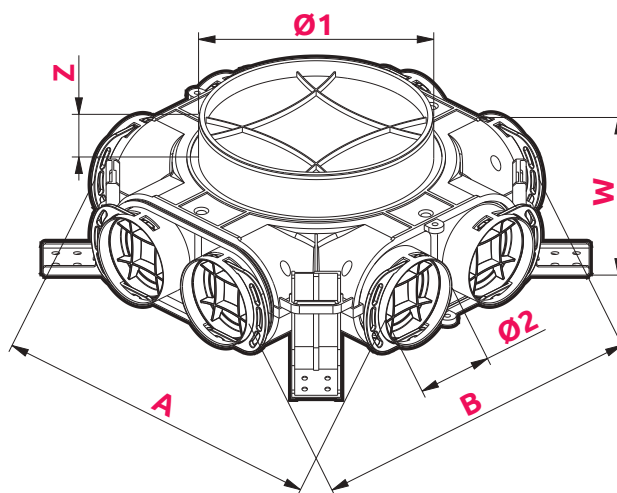

	Ø1	Ø2	A	B	W	Z
VCB160-8	160	75	347	349	104	38
VCB200-8	200	75	347	349	104	38
VCB160-8/90	160	90	407	407	104	38
VCB200-8/90	200	90	407	407	104	38

WITH **NANOSILVER** ADDITIVE
ELIMINATING UP TO 99% BACTERIA

