

Straight-through distribution box

VCB160/200-16

The Awenta PRO VCB straight-through distribution box is designed to distribute the air stream between two floors. Straight-through ducts, Ø160 or Ø200 mm, are used for air flow to the next floor of the building, while Ø75-90 mm ducts enable connection of up to 16 ducts for ventilation of rooms on the lower floor. The air flow between floors is adjusted by means of air valves.

In addition, the user can install a damper upstream of the inlet to the distribution box on the upper floor. Ducts not in use can be closed with the supplied end caps with gaskets.

The AWENTA PRO distribution boxes are equipped with a patented fixing system that enables precise adjustment of the distance between the box and the mounting planes and makes it easy to remove the box if necessary. Independently adjustable brackets allow the horizontal installation of the unit, enabling it to be tilted as well.

VCB series boxes are designed for installation in a heated area of the building; otherwise, they must be insulated with a layer of mineral wool (min. 15 cm). It can be permanently embedded into the screed or ceiling, or installed under plasterboards.



VCB160/200-8

VCB160/200-8/90



	Ø1	Ø2	Ø3	A	B	W	Z
VCB160/200-16	160	75	200	347	927	104	38
VCB160/200-16/90	160	90	200	407	988	104	38

DIMENSIONS

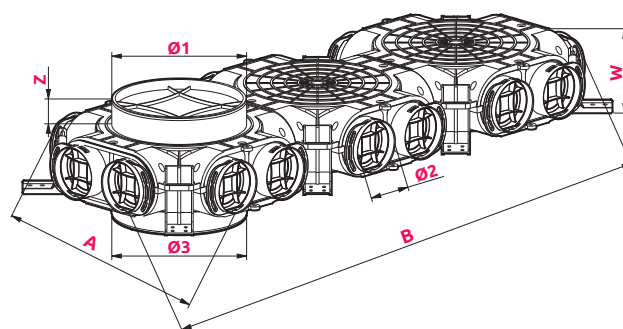

WITH **NANOSILVER** ADDITIVE
ELIMINATING UP TO **99%** BACTERIA

