



OPERATING AND INSTALLATION MANUAL
CENTRAL RECUPERATION UNITS
XHOUSE

TABLE OF CONTENTS

1. General information	5
1.1. Introduction	5
1.2. Warnings and Symbols	5
1.3. Use of the Xhouse unit	6
1.3.1. Unit Designation	6
1.3.2. Prohibited environment, use, installation of the Xhouse unit:	6
1.4. Transport, Delivery Control, and Storage	6
1.4.1. Transport	6
1.4.2. Delivery Inspection	7
1.4.3. Storage	7
1.5. Contents of the Xhouse unit package	7
1.6. Before Commencing the Installation	7
1.7. Technical Parameters	7
1.7.1. Front plastic design cover (position 1)	10
1.7.2. Unit body – fitting (position 2)	10
1.7.3. Hanger for hanging the unit on the wall (position 3)	10
1.7.4. Screw M6x12 with plastic head (position 4)	10
1.7.5. Reinforcement (position 5)	10
1.7.6. Unit cover (position 6)	10
1.7.7. Bolt M6x30 (position 7)	10
1.7.8. Filters (position 8)	10
1.7.9. Filter caps (position 9)	10
1.7.10. Preheating (position 10)	10
1.7.11. Fans (position 11)	10
1.7.12. Recuperator (position 12)	10
1.7.13. Bypass damper (position 13)	10
1.7.14. Controller (position 14)	10
1.7.15. Control box (position 15)	10
1.7.16. Main switch (position 16)	10
1.7.17. Diaphragm multi-grommet (position 17)	11
1.7.18. Screw-in grommet (position 18)	11
1.7.19. Supply cable (position 19)	11
1.7.20. Condensate drain (position 20)	11
1.7.21. Connection sockets (position 21)	11
1.8. Main dimensions of the Xhouse unit	11
2. Technical parameters of Xhouse units	12
2.1. Basic technical parameters	12
2.2. Technical data	13
2.2.1. XH2-030-ECS0HRxxS-0A0 - heat exchanger, electronic bypass	13
2.2.2. XH2-030-ECS0HRxxS-1A0 - heat exchanger, mechanical bypass	14
2.2.3. XH2-030-ECS0ERxxS-0A0 - enthalpy exchanger, electronic bypass	15
2.2.4. XH2-030-ECS0ERxxS-1A0 - enthalpy exchanger, mechanical bypass	16
2.3. Heat and moisture recovery efficiency	17
3. Unit Installation	18

3.1.	General information, recommendations, and safety when installing the Xhouse unit	18
3.1.1.	Electrical safety before installation of the unit	18
3.1.2.	Unpacking the Xhouse unit	18
3.1.3.	Unit Location	19
3.1.3.1.	Location and operation of the unit in the area with a furnace (fire place)	19
3.1.3.2.	Unit Location and Operation in the Area with an Air Conditioning Unit	19
3.1.4.	Minimum installation distances	19
3.1.5.	Installation Positions of the Xhouse unit	20
3.2.	Xhouse Unit Installation.....	20
3.2.1.	Mounting equipment required to install the Xhouse unit - general requirements	20
3.2.2.	Positioning, installation of the unit on the wall.....	21
3.2.3.	Connection of the condensate drain - siphon	21
3.2.3.1.	Connecting the main condensate drain to the siphon.....	22
3.2.3.2.	Connecting an additional condensate drain to the siphon - ventilation in air-conditioned rooms.....	23
3.2.4.	Connecting the air duct to the unit	24
3.3.	Electrical Installation – Connection to Mains.....	24
3.3.1.	General Information – Safety	24
3.3.2.	Connection to Mains	25
3.3.2.1.	Connection of the Unit to the Wiring Box.....	25
3.3.2.2.	Connecting the Unit to the Electrical Outlet.....	25
3.3.2.3.	Recommended Xhouse unit protection	26
3.3.3.	Display of electrical parameters.....	26
4.	Regulation	26
4.1.	General Information – Safety	26
4.2.	Electrical Accessories to the Xhouse Unit	26
4.2.1.	Connecting Electrical Accessories.....	26
4.2.2.	Connection of the CO2 (NL-ECO-CO2) and RH (NL-ECO-RH) sensors - AQS sensors (AQS CO2; AQS RH)	28
4.2.2.1.	Connecting multiple AQS sensors	29
4.2.2.2.	Unit functionality after connection of the AQS sensors	29
4.2.3.	External Contact Connection – EXT 1	29
4.2.3.1.	Technical Parameters of External Contact EXT1	30
4.2.3.2.	Functionality of the Unit when Controlled by External Contact EXT1.....	30
4.2.4.	External Contact Connection – BOOST (EXT2/FILTER)	30
4.2.4.1.	Technical Parameters of External Contact - BOOST.....	30
4.2.4.2.	BOOST regime functionality	30
4.2.5.	Connection of the unit to the parent BMS system using the Modbus RTU protocol	31
4.2.6.	Connecting an external electric heater - (POSTHEATER)	31
4.3.	Block diagram of the Xhouse unit wiring	33
5.	Commissioning	34
5.1.	Prior to first startup, check:	34
5.2.	Activation – Basic Unit Commissioning.....	34
5.3.	Controller Operating Regimes	35
5.3.1.	Sleep Regime – Regular Operating Regime.....	35
5.3.2.	Control Regime – 1 click.....	35
5.3.3.	Unit Setting Regime – 2 clicks.....	35

5.4.	Unit Control	35
5.4.1.	Control panel – controller	35
5.4.2.	Description of the functions of the buttons and regulation	36
5.4.3.	Description of the ventilation power setting range.....	37
5.4.4.	Ventilation Output Settings	37
5.4.5.	Display of the LED Indicated Statuses on the Controller	37
5.4.6.	Hidden Regulation Functions	38
5.4.7.	Automatic Unit Control using AQS Sensors	38
5.5.	Customer Menu	38
5.5.1.	Service Menu Access	38
5.5.2.	Setting the air output for the BOOST regime - 1st screen	39
5.5.3.	BOOST regime run time setting - 2nd screen	39
5.5.4.	Fan distribution setting - 3rd screen	40
6.	Replacing Filters	41
6.1.	Filter Removal.....	41
6.2.	Filter Inserting.....	41
6.3.	Reset filter countdown	42
7.1.	Inspection - cleaning the exterior of the unit.....	43
7.1.1.	Visual Inspection of the Unit Casing.....	43
7.1.2.	Visual Inspection of the Supply Cable	43
7.2.	Inspection - Cleaning of the unit interior	43
7.2.1.	Cleaning the Fan Chamber and Fans	44
7.2.2.	Visual Inspection – Cleaning of the preheater, if fitted with the unit (XH2-030-ECxxxP...)	45
7.2.3.	Visual Inspection and Cleaning of the Heat Recovery Exchanger.....	45
7.2.4.	Re-installation of Internal Components into the Unit	45
8.	Servicing	47
8.1.	Error Messages – Troubleshooting Procedure	47
8.2.	Failure persists.....	48
9.	Final Decommissioning, Dismantling, and Disposal.....	48
10.	Warranty	48
11.	In Conclusion	49

1. General information

1.1. Introduction

- This document “Operating and Installation Manual” is intended for Xhouse central heat recovery units (hereinafter the unit only). At the same time, it is superior to the brief manual placed directly on the unit, so-called “Quick Manual”.



- **Installation and connection of the unit may only be performed by a trained person with the appropriate authorisation for the connection of electrical equipment who has the appropriate tools and resources at his disposal. All the instructions and recommendations provided in this manual must be observed during installation.**
- Detailed familiarisation with this document is important for the unit's correct and safe installation and functioning. Failure to comply with the conditions set out in this document may lead to the unit's malfunction.
- Please, retain this unit installation manual for future reference after reading it thoroughly.
- It is forbidden to interfere in any way with the unit's internal connection other than as specified in this manual. Due to the continuous development of our products, we reserve the right to change this manual without prior notice.
- Children and persons with reduced physical, sensory, or mental capabilities, or lack of experience and knowledge, may use the unit only under supervision or if they were instructed on the unit's use in a safe way and understand potential risks.
- Children may not play with the appliance.

1.2. Warnings and Symbols

- The following names and symbols shall be used in the operating manual, on the packaging, and on the product for particularly important information:



Warning, pay attention to all the risk alerts and warnings, as well as preventive measure instructions.



Danger, observe all the warnings; there is a risk of electric shock or a situation, which can result in death or serious injury, if not prevented.



Reference to other manual sections



Caution – Read Operating Instructions prior to use



Protective conductor connection



Notification of the correct position when handling and storing the packaging.



Notification of the need for protection against moisture. The product – packaging marked with this symbol must not be transported on open vehicles and stored in roofless buildings and on the ground without a pad.



Notification of the content – product's fragility and the need for careful handling of the packaged product.

FRAGILE
KEEP DRY

Notification of the need for protection against moisture and of the fragility of the product inside the packaging.

1.3. Use of the Xhouse unit

1.3.1. Unit Designation

- The Xhouse unit is an air-handling unit using ventilation technology with heat recovery (counter-current heat exchanger) and moisture recovery (enthalpy exchanger) with the possibility of connecting an independent air heater (not included in the unit). The unit can be operated in two ventilation regimes:
 - o Manual - forced ventilation. The unit ventilates according to the power set by the user
 - o Automatic - ventilation according to air quality sensors (AQS). Air quality sensors CO₂ and RH can be connected to the unit (accessories "NL-ECO-CO2" and "NL-ECO-RH"), which allow the unit to ventilate only when necessary. If more sensors are required, up to 8 CO₂ and 8 RH sensors can be connected using the "PRO-SUM-08" accessory. The user only sets the power of the unit (flow rate) according to the required air exchange (number of people) in the ventilated and the unit ventilates according to the actual need.



The unit is equipped with constant flow technology to maintain a stable flow rate in case of varying pipe pressure loss or filter clogging. Which means that it maintains the set flow regardless of the pressure loss, see the graphs in separate chapter 2.2.



The unit can also be connected and controlled remotely by the BMS system using the modbus RTU communication protocol. Addressed in separate chapter 4.2.5.

- The unit can be used for air handling systems with a maximum requirement for a nominal flow of approx. 250 m³/h (depending on the type).
- The unit can be in version "A" fresh air intake on the left side and in version "B" fresh air intake on the right side. Differentiated in unit code eg: XH2-030-ECSOHRPAS-1A0, XH2-030-ECSOHRPBS-1A0.
- The unit is designed for vertical wall mounting only, so that fresh air supply can be provided.
- The unit is intended for continuous operation with the possibility of using the manual operation regime (ventilates continuously) or the automatic operation regime (ventilates as needed – required by the air quality sensors – AQS).
- The unit is intended for indoor covered and dry areas with a room temperature of +5 °C to +30 °C and the maximum relative humidity of 70%, non-condensing.
- The maximum working altitude of the unit is 2,000 m above sea level.
- **The temperature of supplied fresh air from the outside may be between -20 °C and +40 °C (applies to the version with preheating). If the temperature of the supplied air is lower than -20 °C, the unit may be switched off automatically in order to protect it from possible damage.**



1.3.2. Prohibited environment, use, installation of the Xhouse unit:



- **Exhausting burning or glowing substances!**
- **Exhausting readily flammable or explosive gases,**
- **Exhausting aggressive media,**
- **Exhausting liquids of any kind,**
- **In an environment with an increased incidence or risk of explosion, flammable substances, and increased dust and/or air containing other harmful impurities,**
- **In an environment with higher condensation humidity, such as: bathrooms, swimming pools, saunas, etc.,**
- **The unit must not be installed just below the electrical socket or wiring box,**
- Neither the manufacturer nor the supplier is liable for damage caused by improper use of the units (e.g.: drying out of new buildings). The user bears the risk.

1.4. Transport, Delivery Control, and Storage

1.4.1. Transport

- During transport, keep the product in the position indicated by the symbol on the packaging.
- The packaging must not be loaded with a weight higher than that permitted by the manufacturer.
- The packaging must not be exposed to ambient effects.
- The transport air temperature must range between -25 to 55 °C,
- The transport relative humidity must range between 10 % and 90 % non-condensing.



- Use adequate tools to prevent damage to the goods and damage to the health and safety of persons.
- In the case of further transport without original packaging or with changed original packaging, it must be ensured that the equipment is optimally secured and protected against damage.

1.4.2. Delivery Inspection

- Before starting the installation and before unpacking the unit from the box, it is necessary to check for any traces of damage on the packaging. If the packaging is damaged, write a record of the damage and contact your carrier, please.
- Check if you have received the product actually ordered by you. After unpacking, check that the unit and other components are in order. Please, report any discrepancy with the order to the supplier immediately. If an order complaint is not made immediately after delivery, it will not be considered later.

1.4.3. Storage

- If you do not plan to install the unit immediately after purchase, it must be stored in an indoor, non-condensing environment at temperatures ranging between +5 to +40 °C. If the product is transported at temperatures below 0 °C, it must be put into the working environment where it will be installed for at least 2 hours after unpacking.

1.5. Contents of the Xhouse unit package

- | | |
|---|----|
| - Xhouse unit with design cover | 1x |
| - Siphon hose $\varnothing 18/14-1000$ mm for condensate drainage | 1x |
| - 2.5x120tie strap | 2x |
| - Quick manual + safety data sheet | 1x |
| - Serial plate | 1x |
| - Energy label | 1x |

1.6. Before Commencing the Installation

- Before commencing the installation, we recommend that you attach the serial plate (by default, supplied with the package) to the operating documentation (e.g.: equipment operating book, etc.), which is subsequently kept for a later maintenance records and servicing.



- Check that there are no electrical or other lines (e.g. gas, water, etc.) at the point of installation of the unit on the wall that could be damaged during installation.



- Ensure that the installation of the unit, including the openings in the wall for the passage of the connection pipe, does not compromise the building's structure and meets all the legislative safety requirements.

- Check the solution for draining the unit's condensate into the sewer system or in another way that ensures smooth condensate drainage

1.7. Technical Parameters

- Xhouse unit design

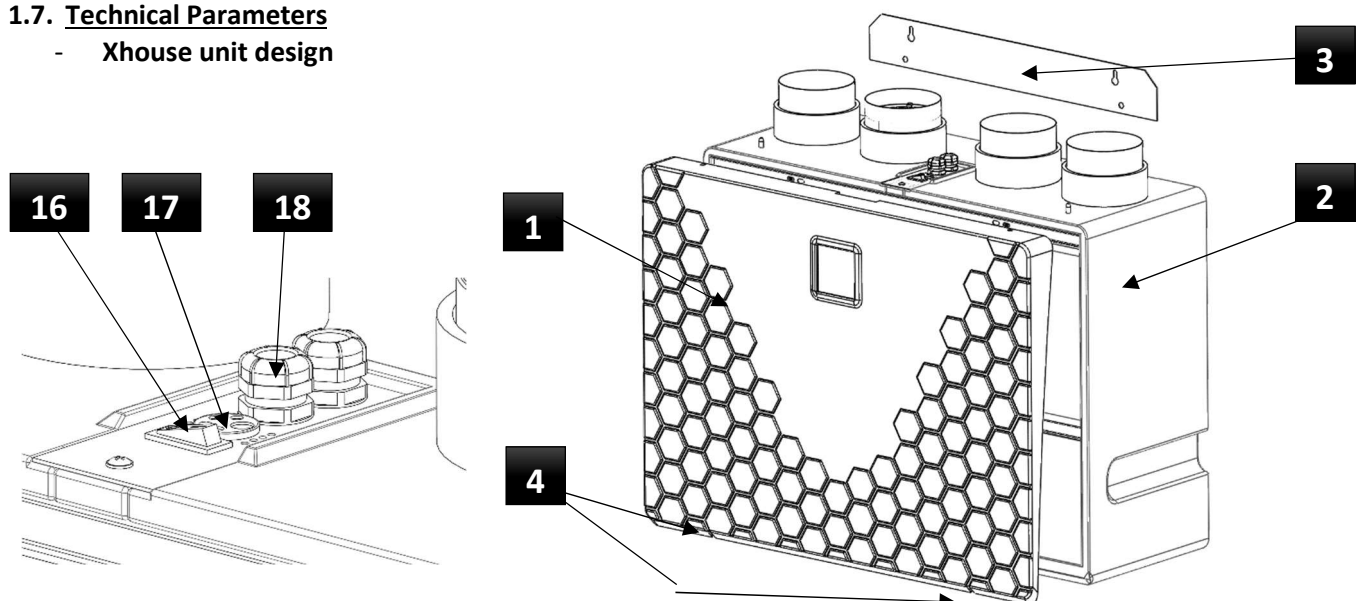

Fig. 1

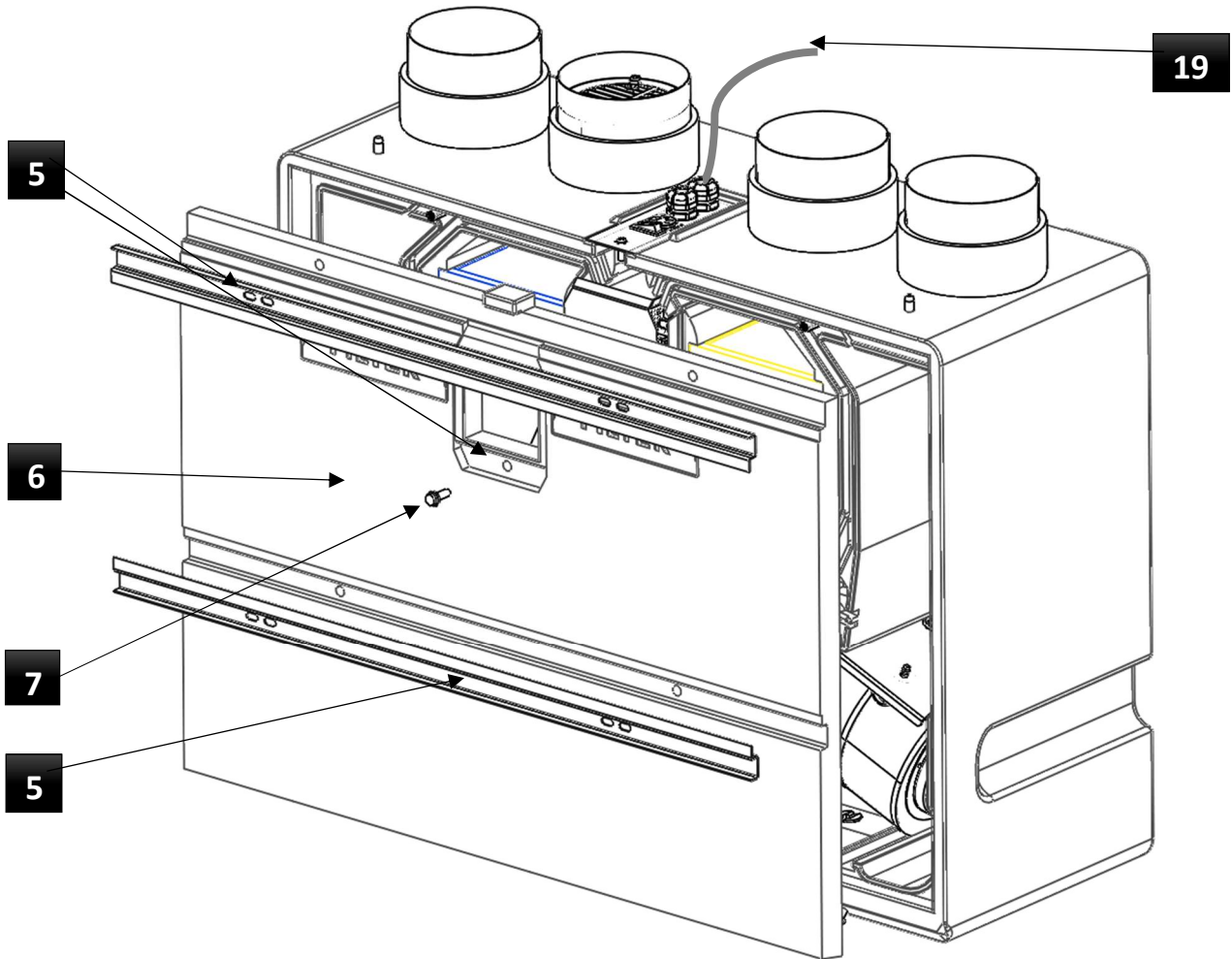

Fig. 2

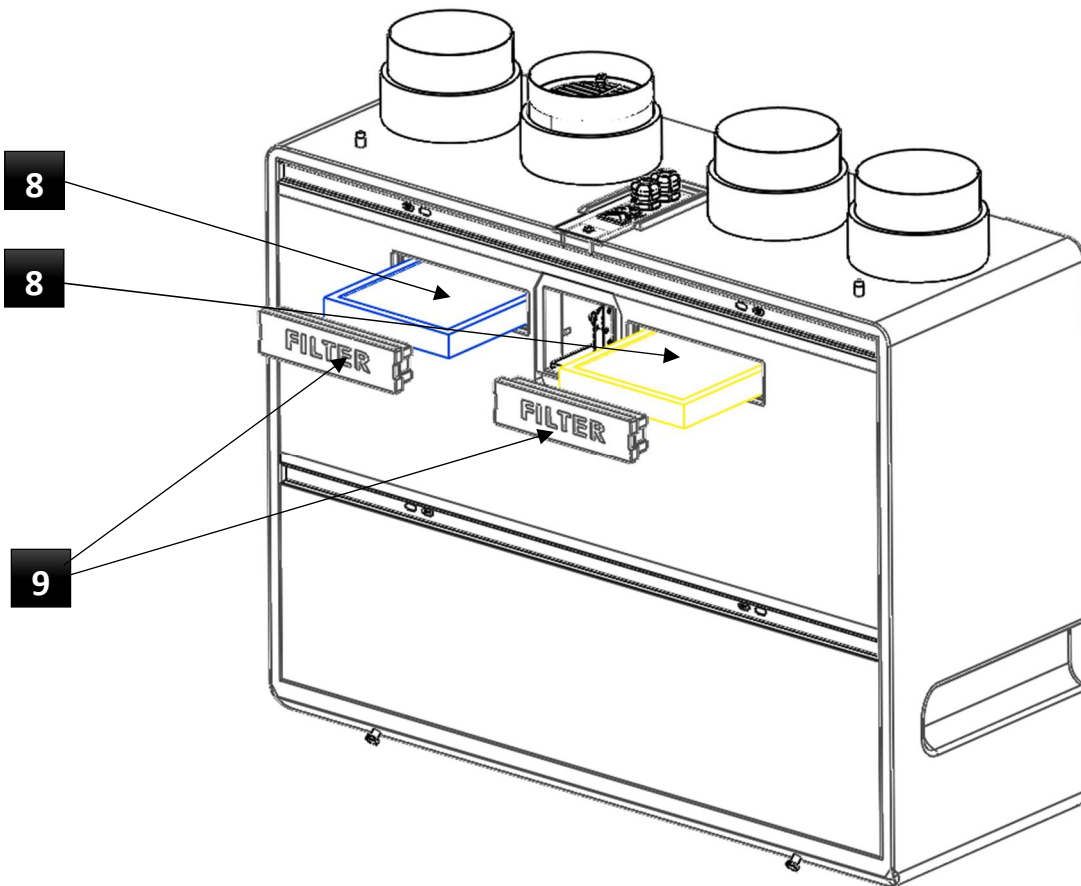

Fig. 3

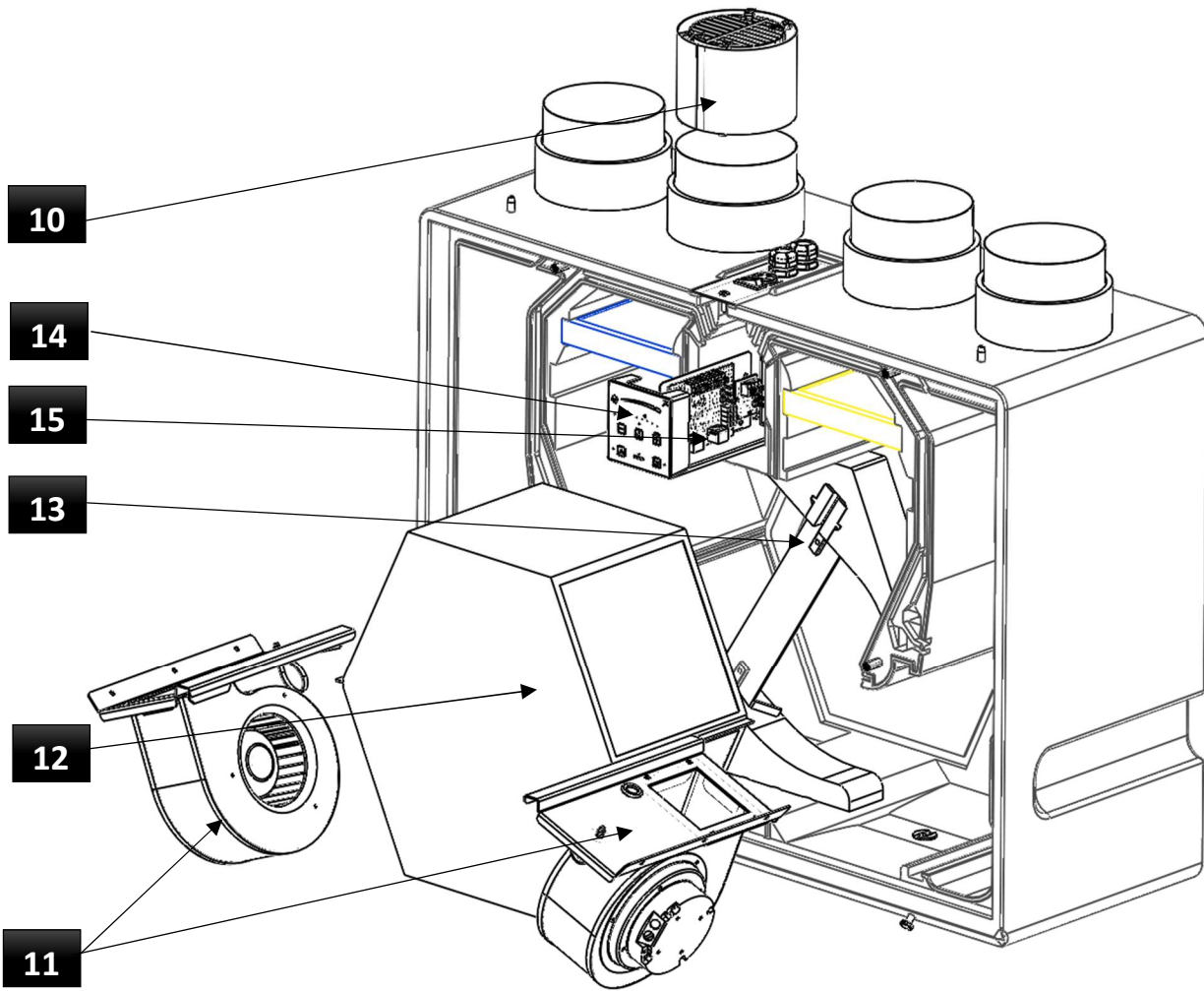

Fig. 4

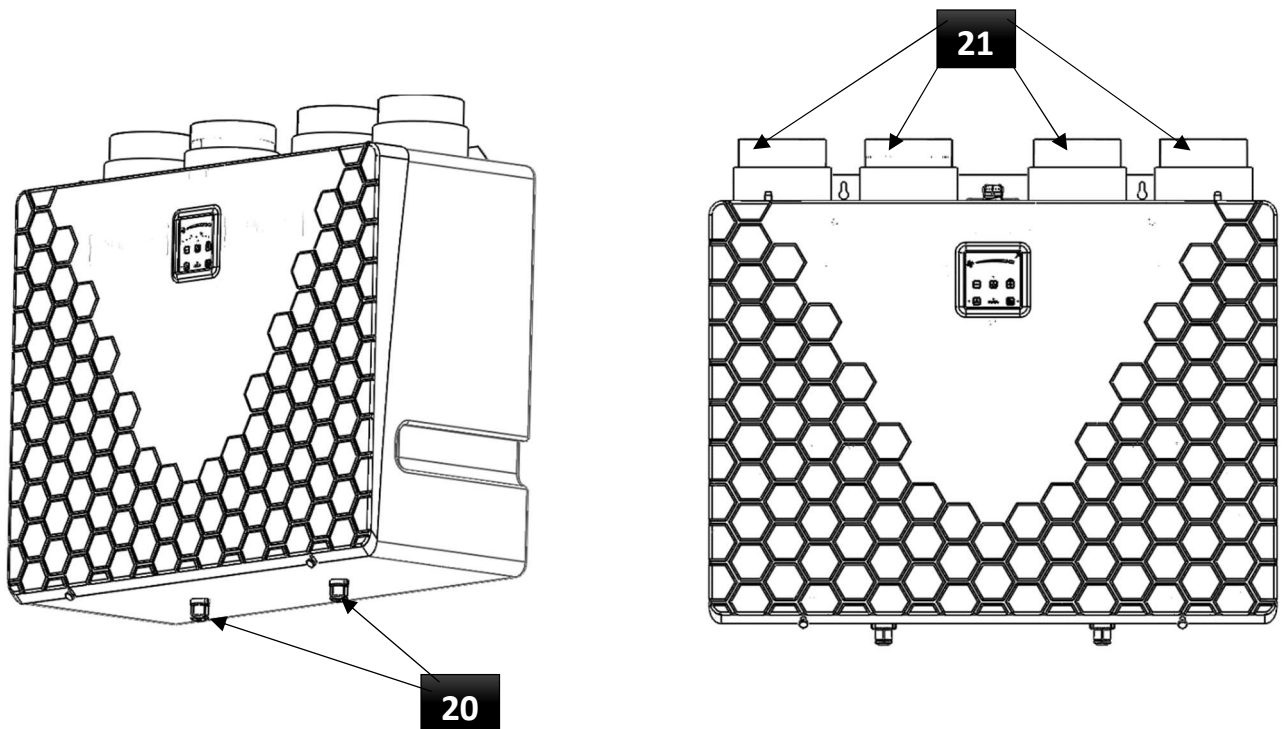

Fig. 5

1.7.1. Front plastic design cover (position 1)

- Plastic cover with the thickness of 2 mm made of ABS material. Standard colour RAL 9003 (white)

1.7.2. Unit body – fitting (position 2)

- The body of the unit is made of black pressed EPP plastic (expanded polypropylene). It ensures the accuracy and repeatability of the installation of components. The material itself is an advanced technical material with a unique combination of properties, such as strength at low weight, rebound elasticity, thermal insulation, chemical resistance, sound insulation, and recyclability.

1.7.3. Hanger for hanging the unit on the wall (position 3)

- The hanger is made of galvanized steel sheet 1.5 mm thick. The hanger is powder-coated to prevent corrosion with RAL 9005

1.7.4. Screw M6x12 with plastic head (position 4)

- The screws are used to manually secure the front plastic cover (position 1)

1.7.5. Reinforcement (position 5)

- Metal reinforcements are made of a 2 mm thick steel sheet with anti-corrosion powder paint RAL 9005.

1.7.6. Unit cover (position 6)

- The unit cover is made of black pressed EPP plastic (expanded polypropylene). It ensures the accuracy and repeatability of the installation of components. The material itself is an advanced technical material with a unique combination of properties, such as strength at low weight, rebound elasticity, thermal insulation, chemical resistance, sound insulation, and recyclability.

1.7.7. Bolt M6x30 (position 7)

- Galvanised M6x30 hex head bolt.

1.7.8. Filters (position 8)

- M5 filters (ISO COARSE 70%) are included in the delivery. F7 filters (ISO ePM1 60%) can be supplied upon request. Evaluation of filters per ČSN EN ISO 16890.

1.7.9. Filter caps (position 9)

- Filter caps are used to seal the filters in the unit cover. They are made of black pressed EPP plastic (expanded polypropylene).

1.7.10. Preheating (position 10)

- Preheating is used to heat the air before it enters the recuperator. It ensures correct ventilation functionality at sub-zero temperatures – anti-freeze protection. It is controlled automatically, based on sensors and regulation.

1.7.11. Fans (position 11)

- The plastic fan with an EC motor and constant flow function from the world's leading manufacturers ensures smooth operation, minimal electricity consumption, and long-term unit life.

1.7.12. Recuperator (position 12)

- The countercurrent recuperator provides heat recovery with the maximum efficiency (XH2-xxx-ECxxHR...). Its version with enthalpy exchanger (XH2-xxx-ECxxER...), it also allows transfer of moisture back to the ventilated area.

1.7.13. Bypass damper (position 13)

- The bypass damper is made of aluminum sheet. The flap is rotated using a 12VDC servo drive. The bypass damper is used to switch the air flow between the recuperator and the bypass of the heat exchanger. It is used especially in the summer months to cool the served area with cool morning air. The units are equipped with a bypass damper according to the type (XH2-xxx-ECxxxxxxxx-1xx). Other units without mechanical bypass are equipped with electronic bypass (XH2-xxx-ECxxxxxxxx-0xx)

1.7.14. Controller (position 14)

- The integrated touch controller on the control box is used to control the entire unit.

1.7.15. Control box (position 15)

- It ensures interconnection of the individual components and also serves for the customer's connection.

1.7.16. Main switch (position 16)

- 1 - pole main switch is used to connect/disconnect the unit from the mains.

1.7.17. Diaphragm multi-grommet (position 17)

- The multi-grommet is used to connect external accessories to the unit while maintaining ingress protection (IP)

1.7.18. Screw-in grommet (position 18)

- It is designed for the passage of a communication cable (e.g.: UTP) to connect the unit to the parent BMS system

1.7.19. Supply cable (position 19)

- It connects the unit and the connection point from the mains. Cable length approx. 1 m. The CYSY 3x1.5 mm² cable type with stripped and marked ends of 50 mm.

1.7.20. Condensate drain (position 20)

- Plastic condensate drain made of ABS material. It is used to drain condensate from the unit.

1.7.21. Connection sockets (position 21)

- The \varnothing 125 mm connection sockets are made of 0.5 mm thick galvanized sheet metal. To increase corrosion resistance, they are powder coated with RAL 9005. The lower part of the sockets is coated with 6 mm thick butyl rubber non-absorbent insulation material to prevent temperature bridges between the socket and the connected piping.

1.8. Main dimensions of the Xhouse unit

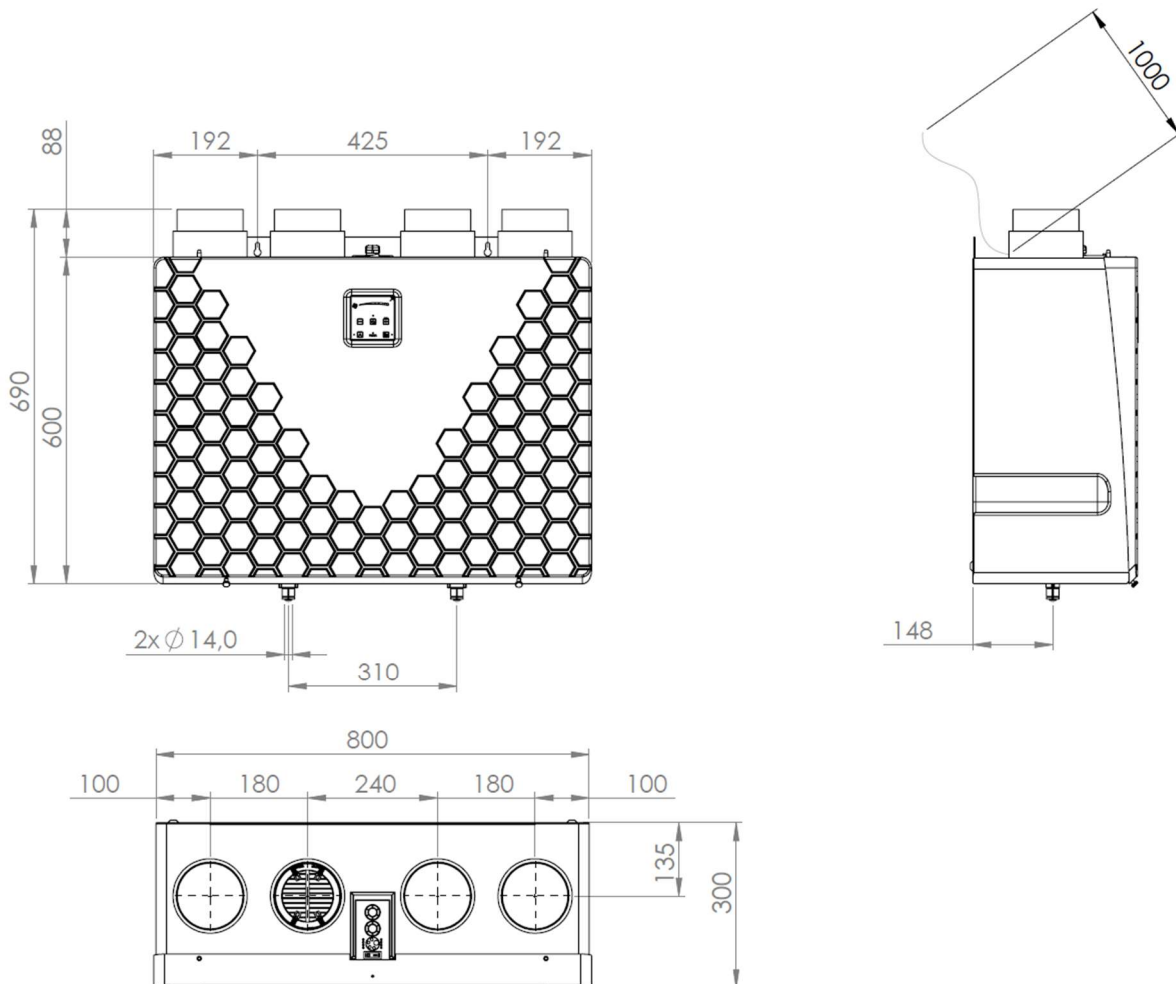

Fig. 6

2. Technical parameters of Xhouse units

2.1. Basic technical parameters

- Basic technical parameters – Xhouse-300 (XH2-030-ECS0HRxxS-xA0) – heat exchanger

Tab. 1

Heat recuperation exchanger - HRV		XH2-30-ECS0HRxxS-0A0	XH2-30-ECS0HRPxxS-0A0	XH2-30-ECS0HRxxS-1A0	XH2-30-ECS0HRPxxS-1A0
Bypass version		Electronic		Mechanical	
Unit equipment - preheater		-	electric	-	electric
Nominal air output* - BOOST**	m ³ /hour	250		250	
Noise level**	dB(A)	37,5		37,8	
Weight****	kg	16,1	17,2	16	17
Power supply of the unit	V/Hz	1 ~ 230 / 50-60			
Nominal unit power consumption* - BOOST**	W	212	812	212	812
Nominal unit current* - BOOST**	A	1,6	4,2	1,6	4,2
Recuperation efficacy *****	%	89,2		88,3	
Protection type	IP	20			
Energy efficiency ratio (ERP)		cold climate A+, medium climate A			

* Nominal air output (power, current) at an external pressure drop of 200 Pa

** BOOST regime - maximum intense ventilation for a set period of time (ventilation intensity and ventilation time can be set in the customer menu)

*** Sound pressure level in free space at the distance of 3 m (Q2)

**** Unit weight without packaging

***** Recuperation efficiency per EN 308; 70% Qv

- Basic technical parameters - Xhouse-300 (XH2-030-ECS0ERxxS-xA0) - enthalpy exchanger

Tab. 2

Enthalpy heat exchanger - ERV		XH2-30-ECS0ERxxS-0A0	XH2-30-ECS0ERPxxS-0A0	XH2-30-ECS0ERxxS-1A0	XH2-30-ECS0ERPxxS-1A0
Bypass version		Electronic		Mechanical	
Unit equipment - preheater		-	electric	-	electric
Nominal air output* - BOOST**	m ³ /hour	250		250	
Noise level**	dB(A)	37,5		37,8	
Weight****	kg	16,6	17,7	16,5	17,5
Power supply of the unit	V/Hz	1 ~ 230 / 50-60			
Nominal unit power consumption* - BOOST**	W	212	812	212	812
Nominal unit current* - BOOST**	A	1,6	4,2	1,6	4,2
Recuperation efficacy *****	heat	76,6		74	
	humidity	54		50	
Protection type	IP	20			
Energy efficiency ratio (ERP)		cold climate A+, medium climate A			

* Nominal air output (power, current) at an external pressure drop of 200 Pa

** BOOST regime - maximum intense ventilation for a set period of time (ventilation intensity and ventilation time can be set in the customer menu)

*** Sound pressure level in free space at the distance of 3 m (Q2)

**** Unit weight without packaging

***** Recuperation efficiency per EN 308; 70% Qv

EC Declaration of Conformity – the current and full version of the EC Declaration of Conformity can be found on our website www.xvent.cz in the “Download Documents” section for the Xhouse product

2.2. Technical data

2.2.1. XH2-030-ECS0HRxxS-0A0 - heat exchanger, electronic bypass

- Airflow / pressure curve

Dia. 1

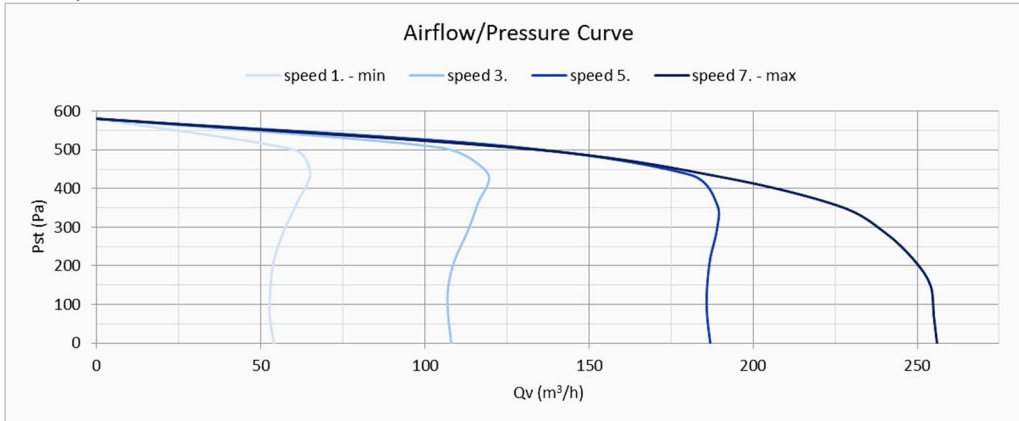

- SFP - specific fan power (W/m³/h)

Dia. 2

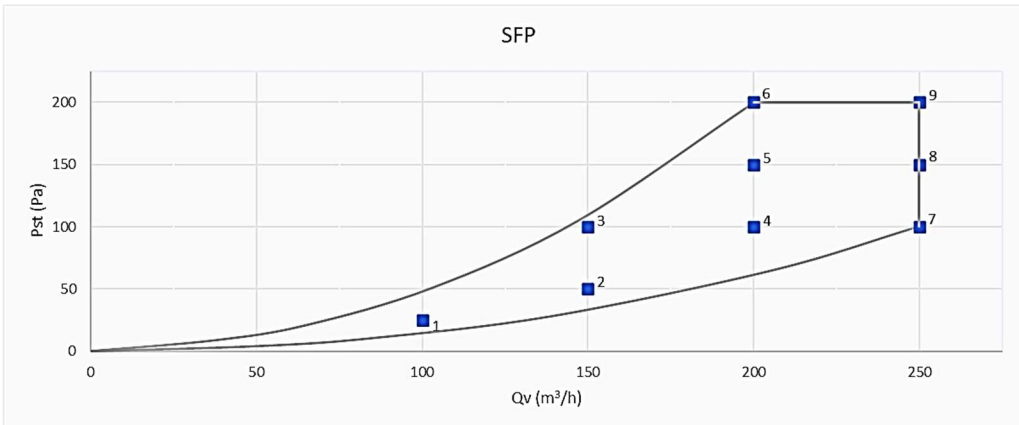

- SFP data (W/m³/h)

Tab. 3

Working points	Air flow	External static pressure	Power	SFP
	(m³/h)	(Pa)	(W)	(W/m³/h)
1.	100	25	19	0,19
2.	150	50	47	0,31
3.	150	100	55	0,37
4.	200	100	103	0,52
5.	200	150	118	0,59
6.	200	200	138	0,69
7.	250	100	174	0,70
8.	250	150	193	0,77
9.	250	200	208	0,83

- unit radiates to the interior (inside the room)

Tab. 4

Degree of air output	Air output	Sound power level LWA [dB (A)]									Sound pressure level in the open field on the reflection plane	
		63 Hz	125 Hz	250 Hz	500 Hz	1 kHz	2 kHz	4 kHz	8 kHz	LWA	1 m	3 m
LED on the controller	(m³/h)	(dBA)	(dBA)	(dBA)	(dBA)	(dBA)	(dBA)	(dBA)	(dBA)	(dBA)	LPA (dBA)	LPA (dBA)
1.	50	-	12,0	23,4	23,6	22,1	14,9	13,0	12,4	31,5	<20	<20
4.	145	25,4	32,5	42,9	39,9	44,6	37,4	32,6	23,2	48,3	34,9	27,0
7. - nominal - BOOST*	250	32,9	41,1	50,1	45,1	49,9	48,2	42,4	33,4	58,9	45,4	37,5

* BOOST mode - intensive ventilation for a set period of time (ventilation intensity and ventilation time can be set in the customer menu)

- unit radiates into the duct - nominal air output

Tab. 5

Connecting sockets	Sound power level LWA [dB (A)]								
	63 Hz	125 Hz	250 Hz	500 Hz	1 kHz	2 kHz	4 kHz	8 kHz	LWA
	(dBA)	(dBA)	(dBA)	(dBA)	(dBA)	(dBA)	(dBA)	(dBA)	(dBA)
ODA	38,9	48,8	44,3	42,5	40,4	31,2	27,0	21,6	59,4
SUP	45,8	50,0	55,2	54,6	51,1	53,9	50,1	46,6	65,9
ETA	38,0	46,6	50,1	43,4	41,5	35,5	28,2	23,1	59,7
EHA	48,8	52,8	55,7	52,7	54,9	53,5	50,7	47,7	66,9

2.2.2. XH2-030-ECS0HRxxS-1A0 - heat exchanger, mechanical bypass

- Airflow / pressure curve

Dia. 4

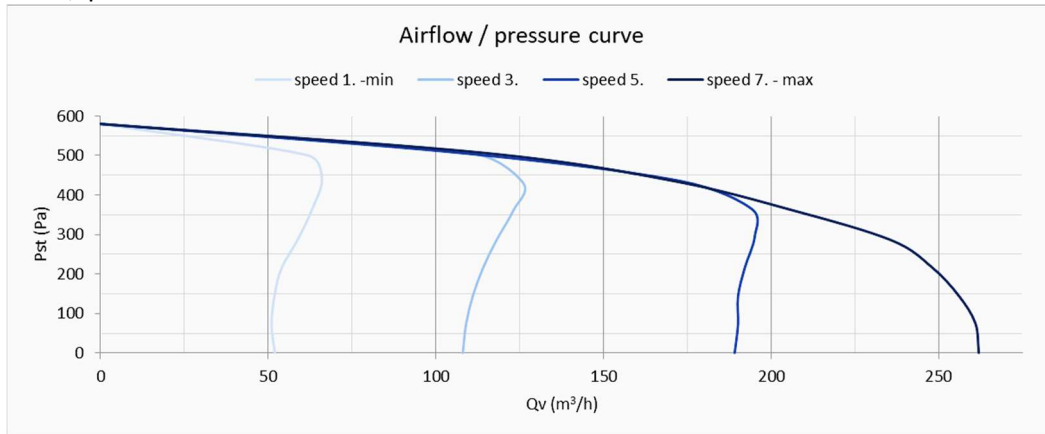

- SFP - specific fan power (W/m³/h)

Dia. 5

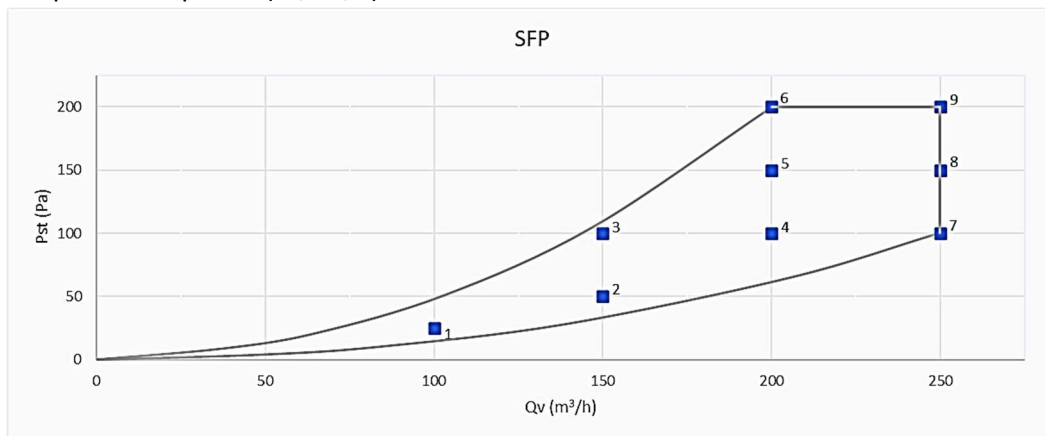

- SFP data (W/m³/h)

Tab. 6

Working points	Air flow	External static pressure	Power	SFP
	(m³/h)	(Pa)	(W)	(W/m³/h)
1.	100	25	19	0,19
2.	150	50	47	0,31
3.	150	100	55	0,37
4.	200	100	104	0,52
5.	200	150	119	0,59
6.	200	200	138	0,69
7.	250	100	175	0,70
8.	250	150	194	0,78
9.	250	200	209	0,83

- unit radiates to the interior (inside the room)

Tab. 7

Degree of air output	Air output	Sound power level LWA [dB (A)]									Sound pressure level in the open field on the reflection plane	
		63 Hz	125 Hz	250 Hz	500 Hz	1 kHz	2 kHz	4 kHz	8 kHz	LWA	1 m	3 m
LED on the controller	(m³/h)	(dBA)	(dBA)	(dBA)	(dBA)	(dBA)	(dBA)	(dBA)	(dBA)	(dBA)	LPA (dBA)	LPA (dBA)
1.	48	-	12,1	23,5	23,7	22,2	15,0	13,1	12,5	31,6	<20	<20
4.	145	25,7	32,7	43,1	40,2	44,9	37,6	32,8	23,4	48,6	35,1	27,2
7. - nominal - BOOST*	250	33,2	41,4	50,4	45,4	50,2	48,5	42,7	33,7	59,2	45,7	37,8

* BOOST mode - intensive ventilation for a set period of time (ventilation intensity and ventilation time can be set in the customer menu)

○ unit radiates into the duct - nominal air output

Tab. 8

Connecting sockets	Sound power level LWA [dB (A)]									
	63 Hz	125 Hz	250 Hz	500 Hz	1 kHz	2 kHz	4 kHz	8 kHz	LWA	
	(dBA)	(dBA)	(dBA)	(dBA)	(dBA)	(dBA)	(dBA)	(dBA)	(dBA)	
ODA	39,2	49,1	44,6	42,8	40,7	31,5	27,3	21,9	59,7	
SUP	46,1	50,3	55,5	54,9	51,4	54,2	50,4	46,9	66,2	
ETA	38,3	46,9	50,4	43,7	41,8	35,8	28,5	23,4	60,0	
EHA	49,1	53,1	56,0	53,0	55,2	53,8	51,0	48,0	67,2	

2.2.3. XH2-030-ECS0ERxxS-0A0 - enthalpy exchanger, electronic bypass

- Airflow / pressure curve

Dia. 5

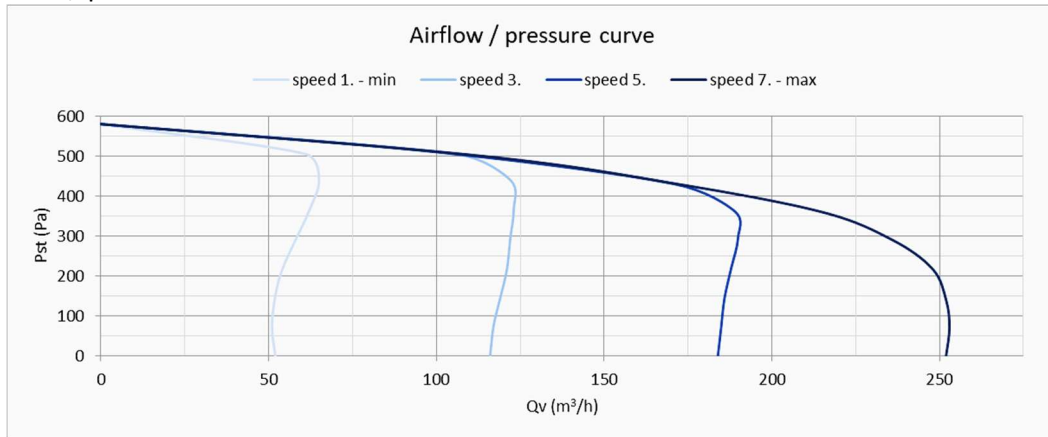

- SFP - specific fan power (W/m³/h)

Dia. 6

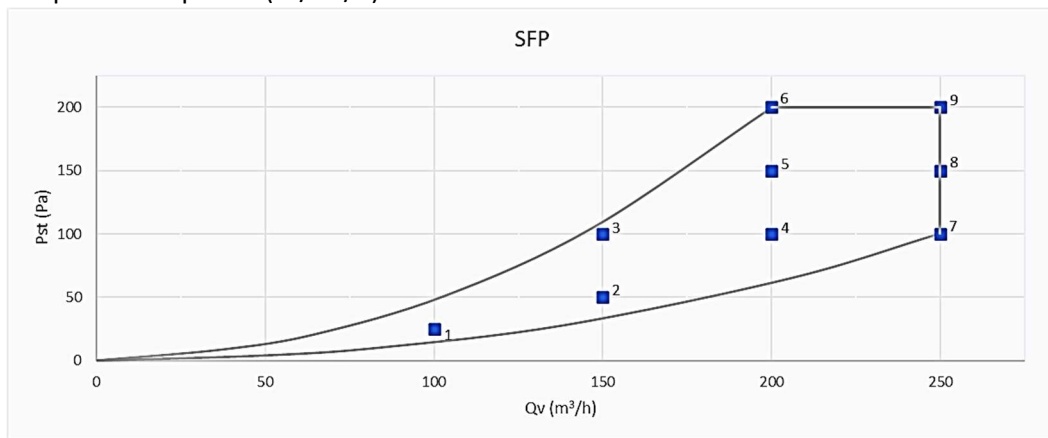

- SFP data (W/m³/h)

Tab. 9

Working points	Air flow	External static pressure	Power	SFP
	(m³/h)	(Pa)	(W)	(W/m³/h)
1.	100	25	20	0,20
2.	150	50	48	0,32
3.	150	100	55	0,37
4.	200	100	104	0,52
5.	200	150	119	0,60
6.	200	200	139	0,70
7.	250	100	175	0,70
8.	250	150	195	0,78
9.	250	200	209	0,84

- unit radiates to the interior (inside the room)

Tab. 10

Degree of air output	Air output	Sound power level LWA [dB (A)]									Sound pressure level in the open field on the reflection plane	
		63 Hz	125 Hz	250 Hz	500 Hz	1 kHz	2 kHz	4 kHz	8 kHz	LWA	1 m	3 m
LED on the controller	(m³/h)	(dBA)	(dBA)	(dBA)	(dBA)	(dBA)	(dBA)	(dBA)	(dBA)	(dBA)	LPA (dBA)	LPA (dBA)
1.	45	-	11,8	23,2	23,4	21,9	14,6	12,8	12,1	31,3	<20	<20
4.	145	25,5	32,6	43,0	40,0	44,7	37,5	32,7	23,3	48,4	35,0	27,1
7. - nominal - BOOST*	250	32,9	41,2	50,1	45,1	50,0	48,2	42,4	33,4	58,9	45,4	37,5

* BOOST mode - intensive ventilation for a set period of time (ventilation intensity and ventilation time can be set in the customer menu)

- unit radiates into the duct - nominal air output

Tab. 11

Connecting sockets	Sound power level LWA [dB (A)]								
	63 Hz	125 Hz	250 Hz	500 Hz	1 kHz	2 kHz	4 kHz	8 kHz	LWA
	(dBA)	(dBA)	(dBA)	(dBA)	(dBA)	(dBA)	(dBA)	(dBA)	(dBA)
ODA	38,9	48,9	44,4	42,6	40,5	31,3	27,1	21,7	59,4
SUP	45,9	50,1	55,3	54,7	51,2	54,0	50,2	46,7	66,0
ETA	38,1	46,7	50,1	43,5	41,6	35,6	28,3	23,1	59,8
EHA	48,9	52,9	55,8	52,8	55,0	53,5	50,8	47,8	67,0

2.2.4. XH2-030-ECS0ERxxS-1A0 - enthalpy exchanger, mechanical bypass

- Airflow / pressure curve

Dia. 7

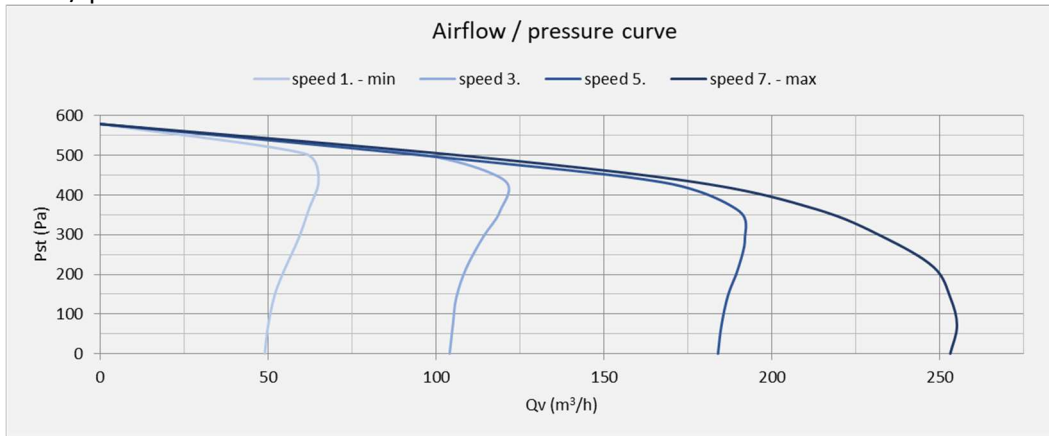

- SFP - specific fan power (W/m³/h)

Dia. 8

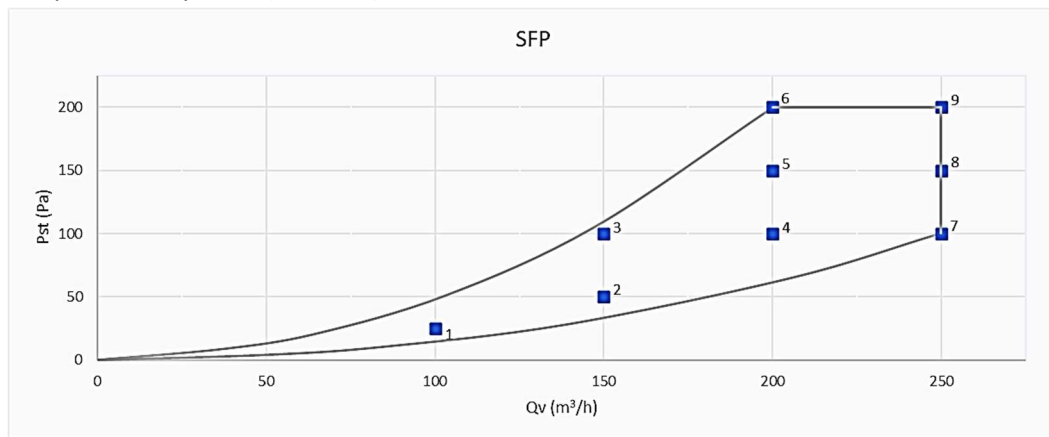

- SFP data (W/m³/h)

Tab. 12

Working points	Air flow	External static pressure	Power	SFP
	(m³/h)	(Pa)	(W)	(w/m³/h)
1.	100	25	20	0,20
2.	150	50	48	0,32
3.	150	100	56	0,37
4.	200	100	105	0,52
5.	200	150	120	0,60
6.	200	200	139	0,70
7.	250	100	176	0,70
8.	250	150	195	0,78
9.	250	200	210	0,84

- unit radiates to the interior (inside the room)

Tab. 13

Degree of air output	Air output	Sound power level LWA [dB (A)]									Sound pressure level in the open field on the reflection plane	
		63 Hz	125 Hz	250 Hz	500 Hz	1 kHz	2 kHz	4 kHz	8 kHz	LWA	1 m	3 m
LED on the controller	(m³/h)	(dBA)	(dBA)	(dBA)	(dBA)	(dBA)	(dBA)	(dBA)	(dBA)	(dBA)	LPA (dBA)	LPA (dBA)
1.	45	-	12,2	23,6	23,8	22,3	15,1	13,2	12,6	31,7	<20	<20
4.	145	25,7	32,8	43,2	40,2	44,9	37,7	32,9	23,5	48,6	35,2	27,3
7. - nominal - BOOST*	250	33,2	41,5	50,4	45,4	50,3	48,5	42,7	33,7	59,2	45,7	37,8

- unit radiates into the duct - nominal air output

Tab. 14

Connecting sockets	Sound power level LWA [dB (A)]								
	63 Hz	125 Hz	250 Hz	500 Hz	1 kHz	2 kHz	4 kHz	8 kHz	LWA
	(dBA)	(dBA)	(dBA)	(dBA)	(dBA)	(dBA)	(dBA)	(dBA)	(dBA)
ODA	39,2	49,1	44,7	42,9	40,8	31,6	27,4	22,0	59,7
SUP	46,2	50,4	55,6	55,0	51,5	54,3	50,5	47,0	66,2
ETA	38,4	47,0	50,4	43,8	41,8	35,8	28,6	23,4	60,1
EHA	49,2	53,2	56,1	53,1	55,3	53,8	51,0	48,1	67,2

2.3. Heat and moisture recovery efficiency

- XH2-030-ECS0HRxxS-xA0 - heat exchanger

Tab. 15

Series		Xhouse-300-efficiency of heat recovery - HRV							
Unit type		XH2-30-ECS0HRxxS-0A0				XH2-30-ECS0HRxxS-1A0			
Bypass type		Electronic				Mechanical			
		FLOW RATE (m ³ /hr)	Temperature % efficiency (EN308)	Current (A)	Power supply (W)	FLOW RATE (m ³ /hr)	Temperature % efficiency (EN308)	Current (A)	Power supply (W)
Degree of air output	1.	50	93	0,10	9	48	92	0,10	9
	2.	70	91,9	0,13	13	73	91,1	0,13	14
	3.	105	90,8	0,20	25	105	90,2	0,21	26
	4.	145	89,9	0,35	47	145	89,1	0,37	50
	5.	190	89	0,65	93	190	87,9	0,70	98
	6.	235	88	1,29	181	235	86,7	1,32	183
	7. - nominál - BOOST*	250	87,7	1,48	210	250	86,3	1,52	211

* BOOST mode - intensive ventilation for a set period of time (ventilation intensity and ventilation time can be set in the customer menu)

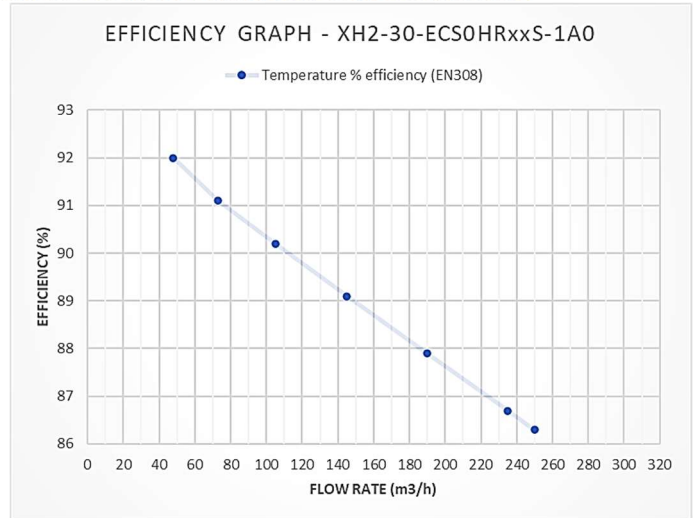
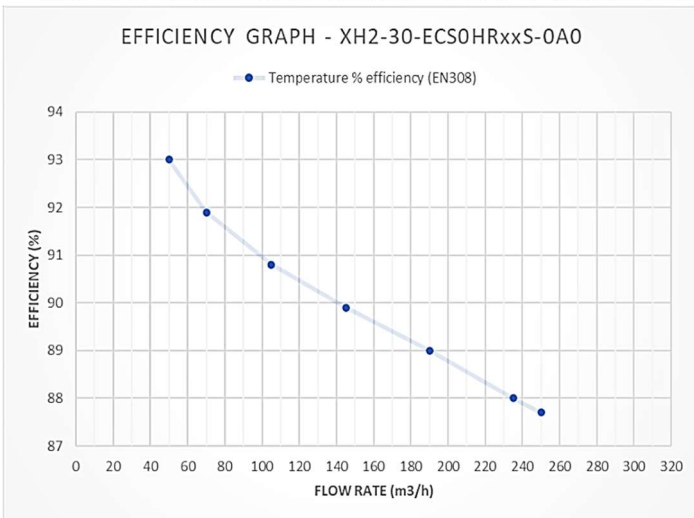

- XH2-030-ECS0ERxxS-xA0 - enthalpy exchanger

Tab. 16

Series		Xhouse-300-efficiency of heat and humidity recovery - ERV									
Unit type		XH2-30-ECS0ERxxS-0A0					XH2-30-ECS0ERxxS-1A0				
Bypass type		Electronic					Mechanical				
		Flow rate (m ³ /h)	Temperature % efficiency (EN308)	Humidity efficiency % (EN308)	Current (A)	Power supply (W)	Flow rate (m ³ /h)	Temperature % efficiency (EN308)	Humidity efficiency % (EN308)	Current (A)	Power supply (W)
Degree of air output	1.	45	91,3	50	0,10	8	45	89,8	50	0,11	9
	2.	73	88,5	48	0,14	14	73	86,6	46,5	0,16	15
	3.	105	85,4	45,5	0,21	25	105	83,3	43,7	0,21	25
	4.	145	82,3	42,8	0,37	50	145	80,2	40,5	0,38	50
	5.	185	80	40,3	0,69	94	185	77,8	37,6	0,69	95
	6.	235	77,7	37,4	1,30	182	235	75,6	34,2	1,31	183
	7. - nominál - BOOST*	250	77,1	36,5	1,49	211	250	75	33,2	1,54	212

* BOOST mode - intensive ventilation for a set period of time (ventilation intensity and ventilation time can be set in the customer menu)

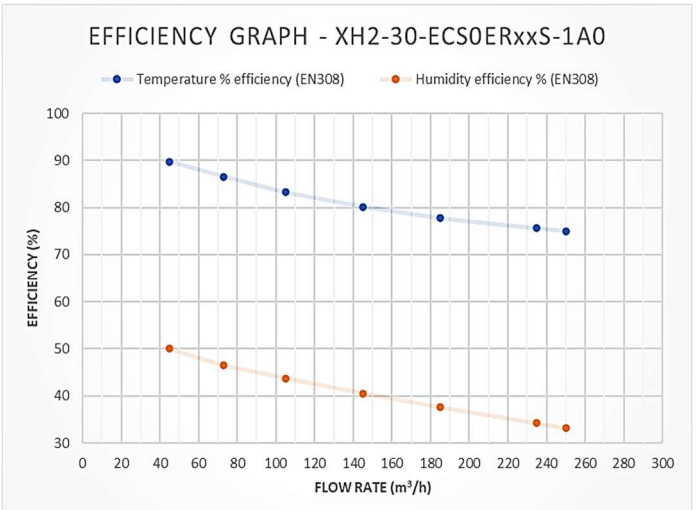
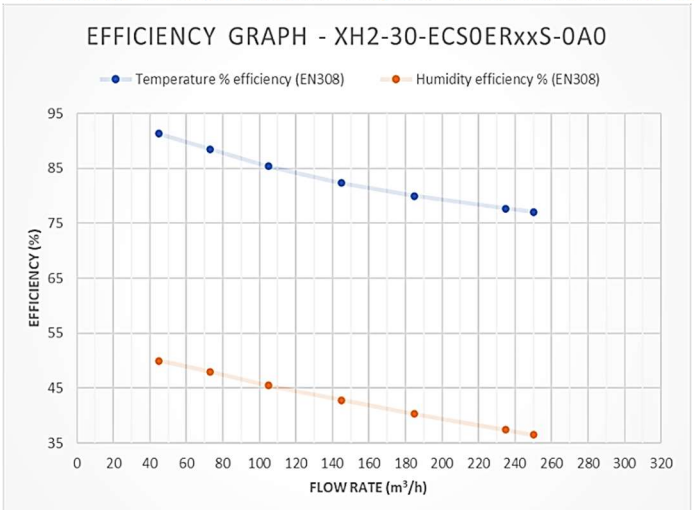

3. Unit Installation

3.1. General information, recommendations, and safety when installing the Xhouse unit

3.1.1. Electrical safety before installation of the unit



- Before starting any installation work, make sure that the wiring box or mains socket that you want to use to connect the unit is equipped with a protective (green-yellow) wire or contact (pin).
- If you use a wiring box to electrically connect the unit, you must turn off the power and secure the power supply against accidental turn on.



Check that the electrical connection point (wiring box, outlet) meets the unit's power supply requirements (voltage, current, etc.) specified on the unit's serial plate. The electrical quantities necessary for the unit's operation can be found in Section 3.3.3. "Display of electrical parameters"

3.1.2. Unpacking the Xhouse unit

- Always unpack the unit in a sufficiently large area to allow for removing the unit from the packaging.
- Never unpack the entire unit from the packaging, the unpacking of the unit must be gradual, as specified in this manual according to the installation work in progress (protection of the unit from damage and dust generated during installation)

- Follow these steps:

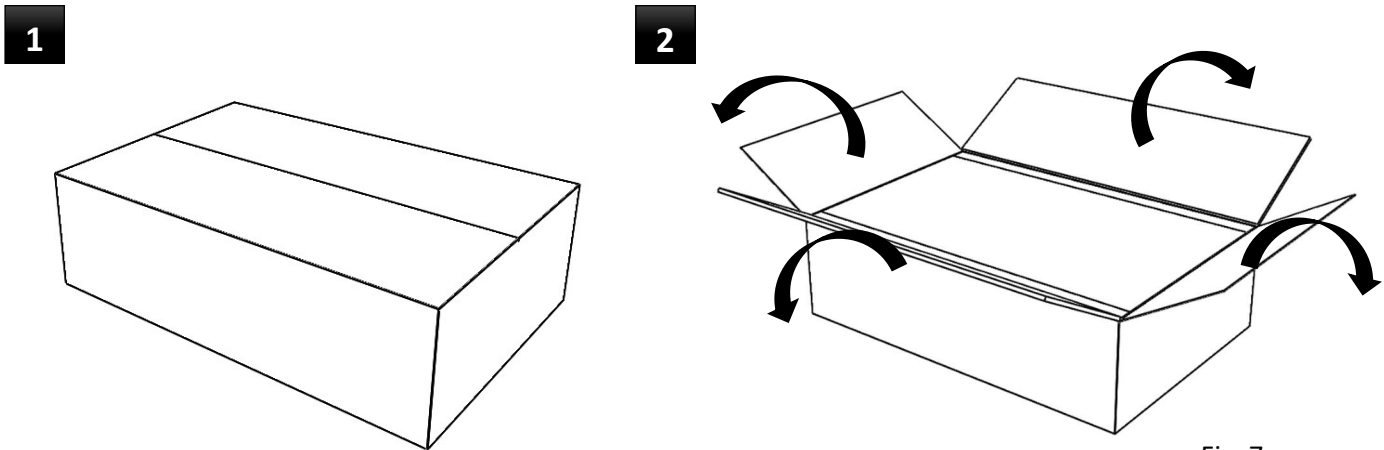

Fig. 7

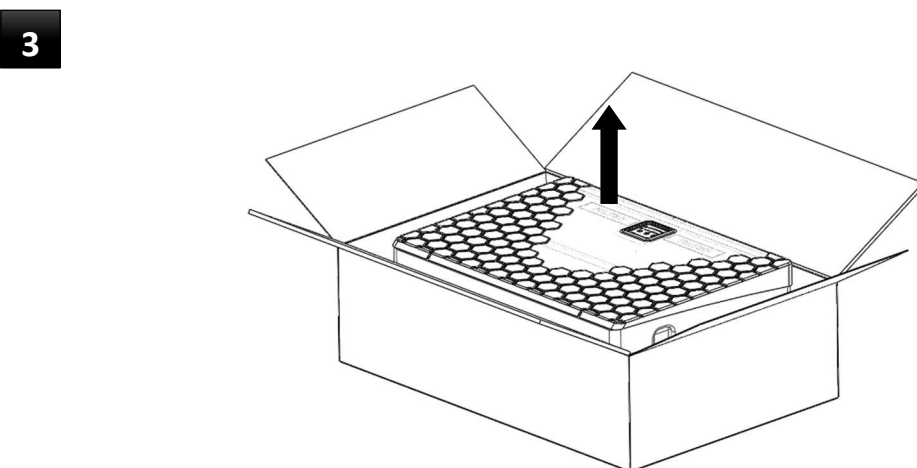



Fig. 8



Please, return all the not needed packaging to the appropriate recycling points where they will be disposed of professionally. Only packaging recycled in this way can be reused properly and returned to utility.



3.1.3. Unit Location



- When selecting a location for the installation of the unit, always consider the layout of the building within the overall HVAC system (e.g.: location of dampers, supply and exhaust ducts, etc.). Consult an HVAC designer or a person knowledgeable in the field for the proper design of the entire HVAC system. **The manufacturer is in no way responsible for the design of the ventilation system.**

- The unit is to be installed in indoor covered and dry areas with a room temperature of +5 °C to +30 °C and with maximum relative humidity of 70% non-condensing.



Consider the location of the unit indoor away from surrounding objects in relation to the recommended clearances from the unit (e.g.: filter changes, opening the unit - servicing) as given in chapter 3.1.4. Minimum installation distances

- Check your options for connecting the condensate outlet to the waste piping.

3.1.3.1. Location and operation of the unit in the area with a furnace (fire place)

- If the air ducts are located in rooms with a furnace, you can set the fan distribution in the customer menu (more air is supplied than exhausted). The fan balancing cannot replace the separate air supply to the heater in any way due to the possibility of controlling by AQS sensors.
- For proper operation of the furnace and the unit, consult the location with the chimney sweep. Otherwise, the unit may malfunction.

3.1.3.2. Unit Location and Operation in the Area with an Air Conditioning Unit

- When operating the unit during the summer months and using the air conditioner in a ventilated area, condensation may form inside the unit in the opposite supply branch. In this case, it is necessary to connect a siphon and subsequent condensate drain to the supply branch.
- The unit is equipped with a plugged outlet for siphon connection as standard. For more information see Chapter 3.2.3.
- For trouble-free operation, we recommend installing a unit equipped with an enthalpy exchanger (XH2-030-ECS0ER...).

3.1.4. Minimum installation distances

- Distances from fixed objects:

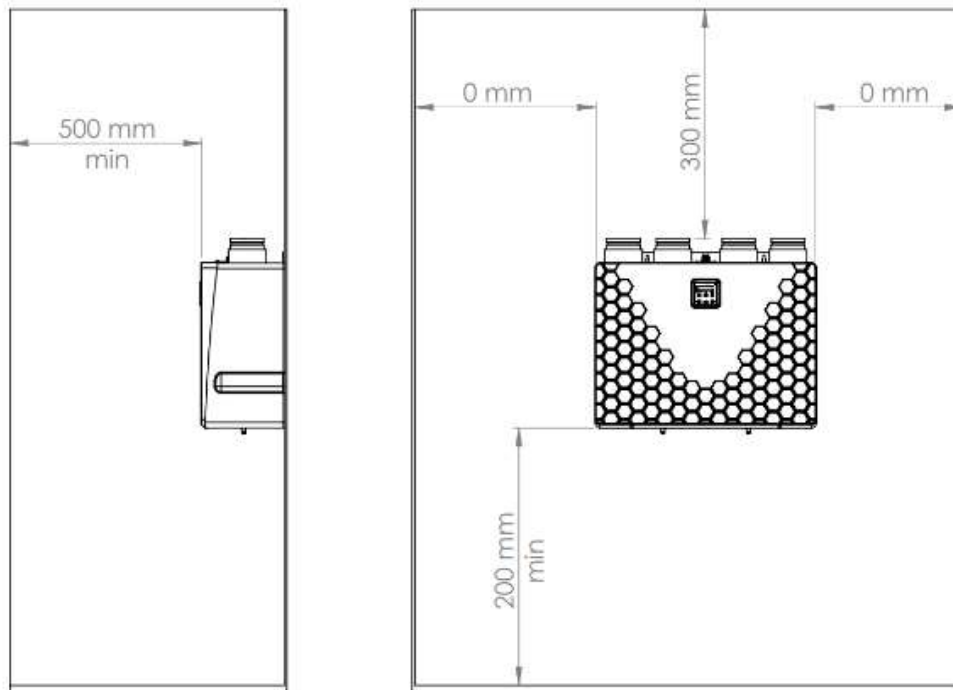

Fig. 9

- The unit must be installed in such a way that the direction of air flow through the unit itself is the same as the air flow in the air handling system.
- Failure to observe the specified clearances may not work properly and may damage the fan, increase noise, or prevent service access to the unit.

3.1.5. Installation Positions of the Xhouse unit

- All the Xhouse unit types can be installed in the following position:

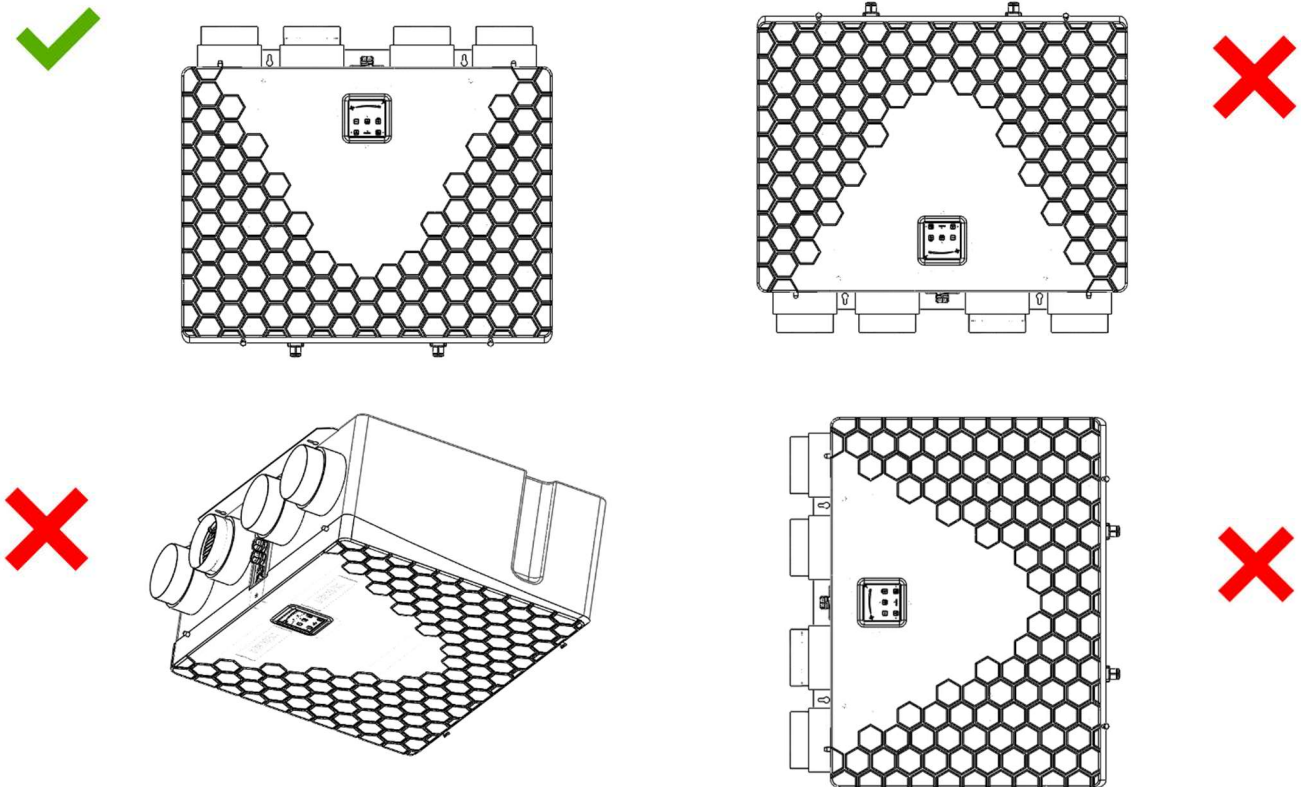

Fig. 10



- **Any other position is prohibited**

3.2. Xhouse Unit Installation

- The unit must be operated in enclosed and dry areas with room temperature ranging between +5 °C and +30 °C.
- The recovery unit must be installed in accordance with the general and local safety regulations.
- The recovery unit may be installed, connected, commissioned, and repaired by a person with adequate education, experience, and knowledge of applicable regulations, standards, and potential risks and hazards, or by a properly trained service technician.



- **Failure to follow the installation procedure may result in the unit's damage or malfunction, or potential harm to the health and property of the user.**
- **Take special care when installing the condensate drain via a condensation sump (not a part of the supply) into the sewerage piping. The unit manufacturer accepts no liability for damage caused by incorrect installation of the condensate sump, drain piping, and other peripherals required for their operation.**

3.2.1. Mounting equipment required to install the Xhouse unit - general requirements

- Prepare mounting aids (not included) to install the unit:
 - o Anchoring elements (e.g. dowels, dowel screws) 2 pcs
- Select the anchoring material according to the wall construction, unit weight, and the weight of the connected peripherals.



The unit variant weights are given in item 2.1. "Basic technical parameters"
 The unit dimensions are given in item 1.8. "Main dimensions of the Xhouse unit"

3.2.2. Positioning, installation of the unit on the wall

- Select the appropriate anchoring material (not included) for the given wall. To use the unit's hanging system (keyhole), choose a screw with max. $\varnothing 7$ mm with the maximum head diameter up to 13 mm.
- Use a spirit level to measure the anchor holes for attaching the unit to the wall. Alternatively, place the unit on the wall with a spirit level, level it, and mark the mounting holes for anchoring the unit.

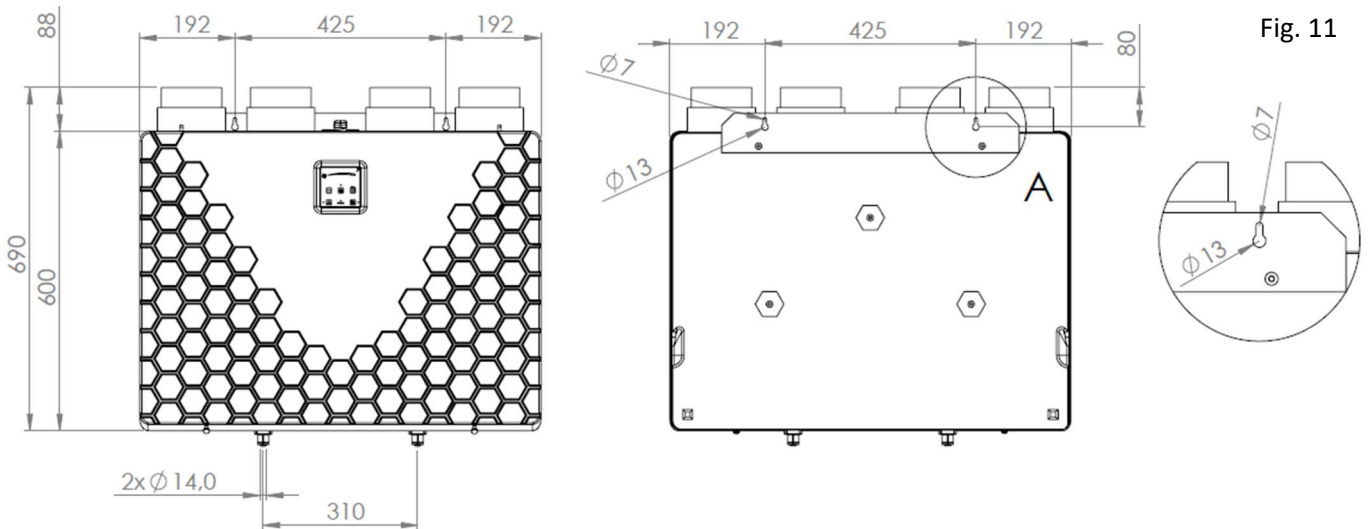

Fig. 11



- **The wall into which you anchor the unit should always be sufficiently strong and cohesive. If necessary, contact a specialist in the field - structural engineer.**
- Drill holes in the wall and partially screw in the screws for hanging the unit.
- Mount the unit onto the prepared anchor bolts.

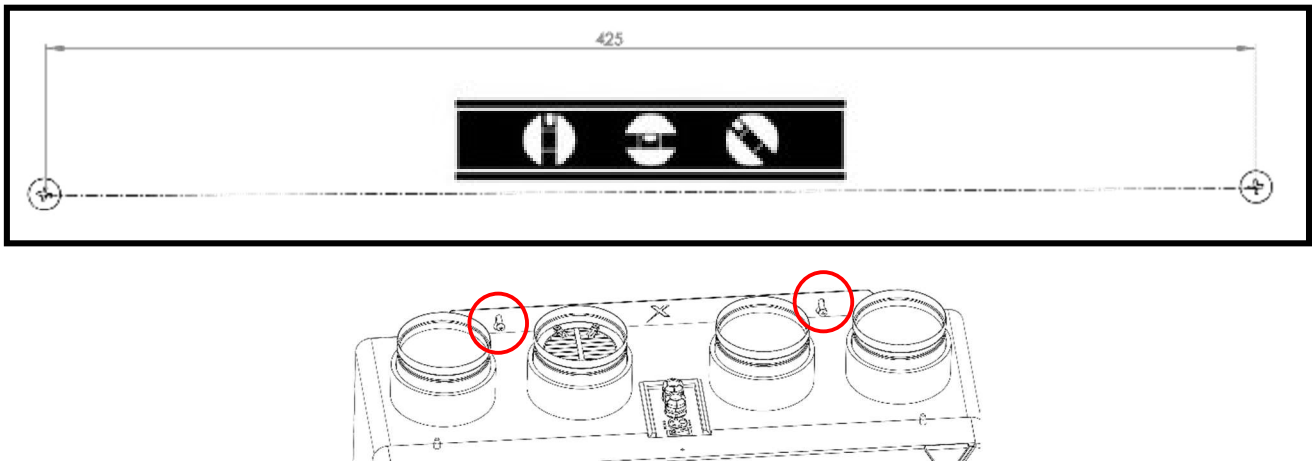

Fig. 12

- Tighten the anchor bolts adequately to secure the unit against any undesired movement - falling.

3.2.3. Connection of the condensate drain - siphon

- The unit must always be fitted with a siphon (included in the delivery) connected to a sewer system.
- Always check the watering of the siphon and the condensate drainage before starting up for the first time or after shutting down the unit (the unit has been switched off for a long time).
- The unit is equipped with two condensations drains:
 - o Main drain - must always be plugged, designed to drain condensate from the unit as standard. The outlet is open as standard.

- Additional drain - used to drain condensate from the supply branch - ventilated area with air conditioning. The outlet is blinded as standard. If an additional drain is used, both outlets must be connected.

- version "A" fresh air intake on the left side
(eg: XH2-030-ECS0HRPAS-1A0)

- version "B" fresh air intake on the left side
(eg: XH2-030-ECS0HRPBS-1A0) Fig. 13

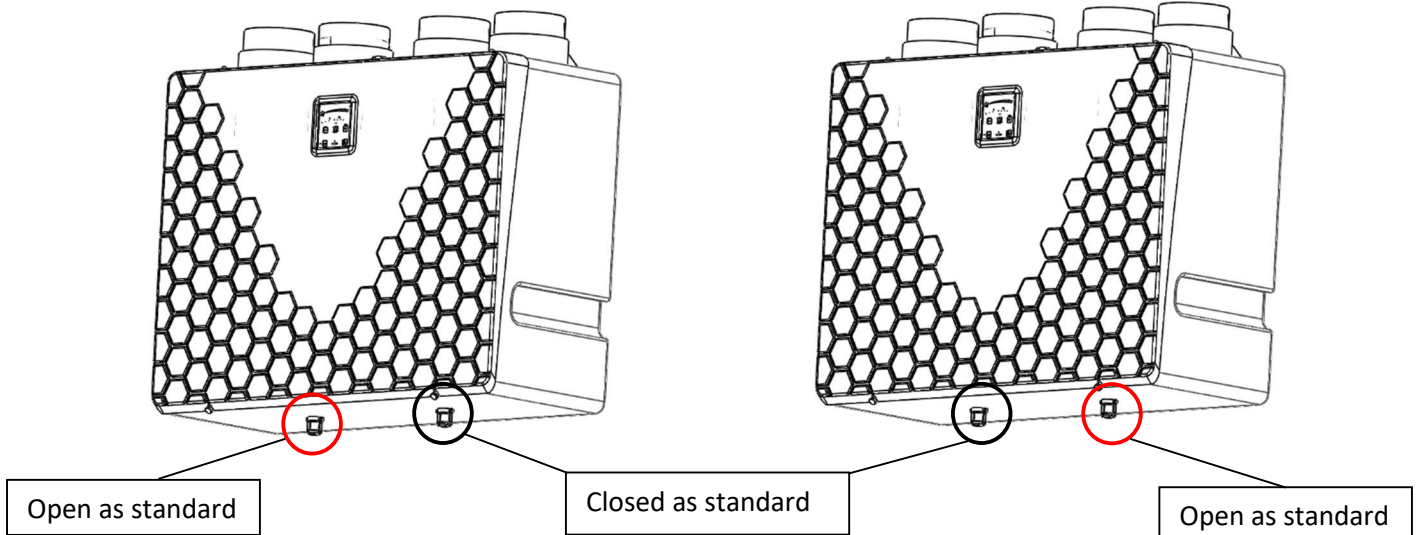

- **The siphon must always be watered, well connected, and sealed to the unit drain, otherwise there is a risk of condensate not draining from the unit and thus condensate accumulating in the unit with a possible overflow of the condensate tray. This can subsequently lead to property damage.**

3.2.3.1. Connecting the main condensate drain to the siphon

- Remove the PVC siphon hose \varnothing 18/14- 1000 mm and 2 pcs of 2.5x120 mm tie strap from the unit package
- Create a 150 mm diameter loop, approximately halfway along the siphon hose.
- Secure the loop with 1 piece of tie strap, against any undesired movement, but at the same time so as not to deform (break) the siphon hose

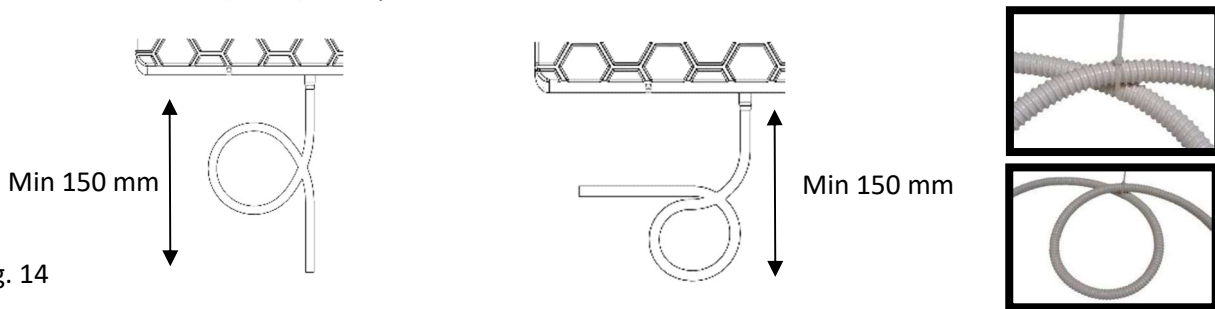

Fig. 14



- **Pay particular attention to maintaining a loop diameter of 150 mm and using adequate force when tightening the tie strap. If these requirements are not met, there is a risk of condensate not draining from the unit and thus condensate accumulating in the unit with a possible overflow of the condensate pan. This can subsequently lead to damage to the user's property and health.**
- Water the siphon - pour water into the siphon from the drain connection side of the unit until water flows out the other side of the siphon.
- Fit the fabricated siphon to the main drain.
- Orient the formed siphon loop so that it functions as a water trap.

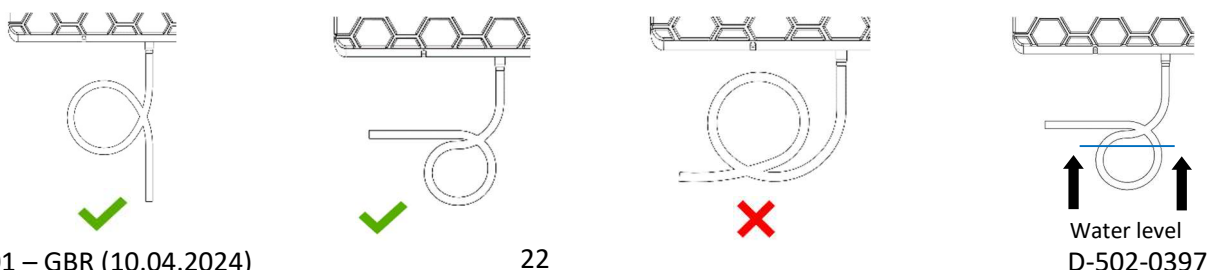

Fig. 15



- When creating a bend - elbow on the siphon hose, make sure to keep the correct bend radius of the hose to avoid “breaking” the hose and consequently choking the hose and preventing condensate drainage.
- Secure the formed siphon with a second 2.5 x 120 mm tie strap (included) to the main drain located on the unit.

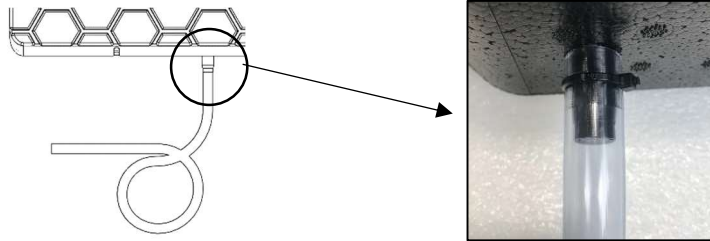

Fig. 16

- Adjust the other end of the siphon hose in length and connect - secure into the sewer system, keeping the minimum height difference between the siphon hose and the sewer connection.

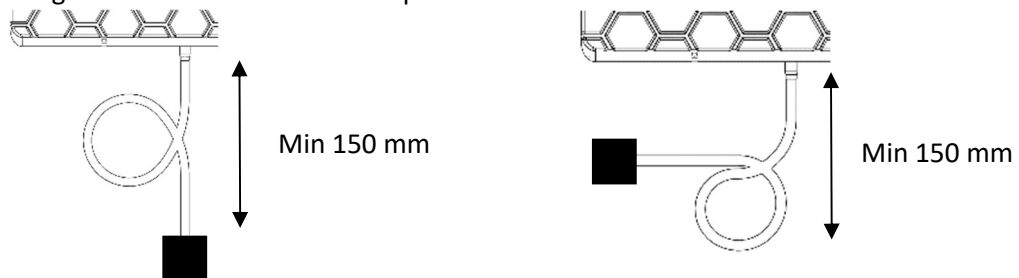

Fig. 17



- Extension of the siphon hose is only permissible beyond the hose loop created. Extend with a hose of the same or larger diameter using a hose connector. Always ensure the smallest possible reduction of the inner diameter with the hose coupling.

3.2.3.2. Connecting an additional condensate drain to the siphon - ventilation in air-conditioned rooms

- The unit is equipped with an additional - second condensate drain on the fresh air supply to the building. The connection of this outlet is necessary especially in buildings that are cooled by air conditioning in summer, where there is a large difference between the outdoor intake temperature (e.g.: 35°C) and the indoor exhaust air temperature (e.g.: 22°C) with outdoor humidity above 60%.
- Cut off the end of the additional condensate drain 5 mm long.

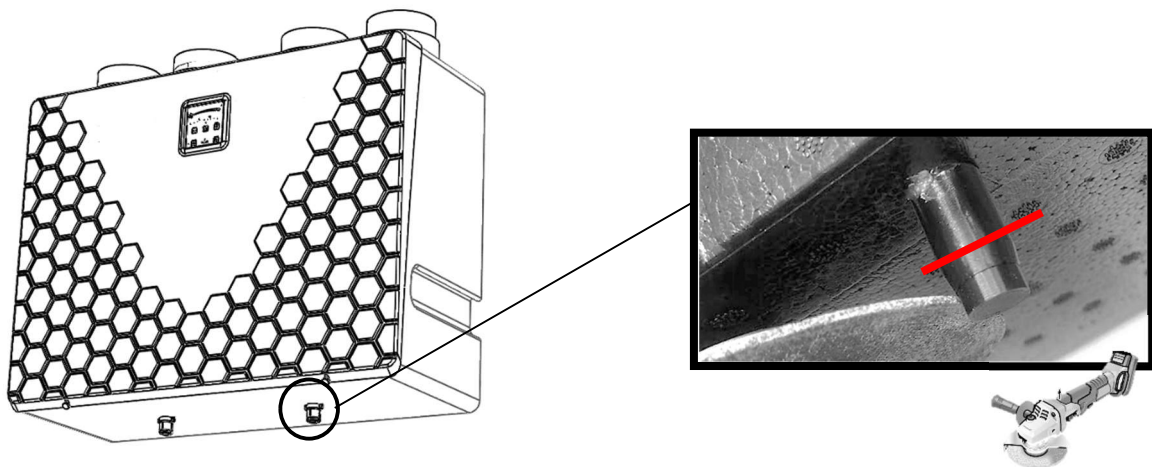

Fig. 18

- Make sure you have the same drain hose (PVC - Ø 18/14) as for the main drain connection and 2 pcs of locking ties.



Create a loop to form a siphon and connect to the additional drain as per chapter 3.2.3.1.
Connect the ends of the siphons - ends of the hoses to the sewer system, if possible at the installation site:

- Connecting the two ends of the siphon into one and then connecting it to the sewer system

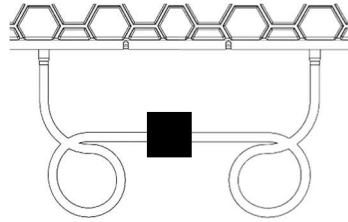

Fig. 19

- Connect every end of the siphon separately to the sewer system

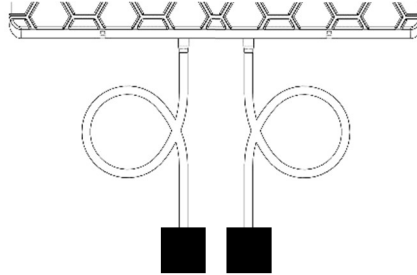

Fig. 20

3.2.4. Connecting the air duct to the unit

- The diameter of the socket of the unit for connection of the distribution pipe is 125 mm. The sockets are fitted a thermal sleeve for better connection of the pipe insulation to the neck (thermal bridge breaking). Connect the pipe to the sockets up to the heat sleeve on the socket.
- Seal the joints with aluminium tape or connecting sleeves to prevent vibration transmission.
- Insulate the pipes with thermal insulation material (rock wool, butyl rubber etc...).
- Pull the pipe insulation at the socket over the heat sleeve at the socket and secure against any undesired movement.
- determination of nozzles version "A" fresh air supply on the left side (eg: XH2-030-ECS0HRPAS-1A0)
- determination of nozzles version "B" fresh air supply on the left side (eg: XH2-030-ECS0HRPBS-1A0)

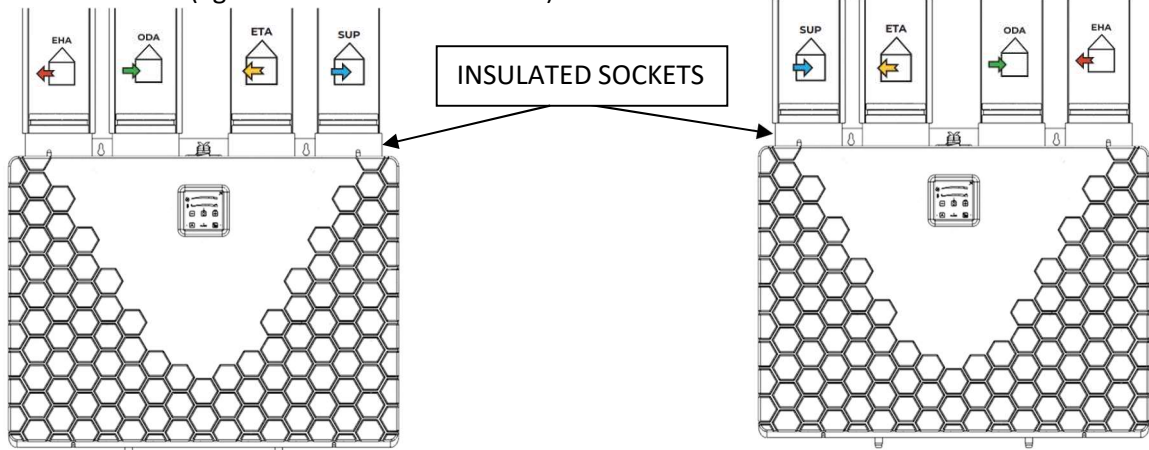

Fig. 21

- All the pipe joints that are connected to the unit must be sufficiently sealed to prevent unwanted leaks and subsequent problems such as condensation.
- The connected piping must be of the same diameter as the unit's connecting sockets. If smaller diameter piping is used, this may affect the air performance of the unit and may reduce the life of the fans.

3.3. Electrical Installation – Connection to Mains

3.3.1. General Information – Safety



- Before starting all the installation work, make sure that the wiring box or mains power outlet that you want to use to connect the unit is equipped with a protective (green-yellow) wire or contact (pin).
- If you use a mains plug to connect the unit, it must always remain accessible so that the unit can be safely disconnected from the mains in the event of danger.



- Check that the power supply meets the requirements for power supply of the unit (voltage, current, frequency, etc.) specified on the unit's serial plate. Section 3.3.3. Displaying the Electrical Parameters.

- The relevant current circuit must be protected in the electric power distribution system by the maximum of 16 A.
- The electrical cable to be connected to the mains must not be broken.
- Local electrical regulations must always be respected.
- Electrical connection of the unit to the mains may only be carried out by persons qualified for this activity with a valid authorisation and knowledge of relevant standards and directives in the country.
- Before starting any installation work, it is necessary to switch off the power supply. During the installation, the switch must be secured against being switched on again by an unauthorised person. The switch must have the minimum contact spacing of 3 mm.
- A two-pole disconnecting means (circuit breaker) must be connected to the unit's supply.
- It is forbidden to interfere in any way with the internal connection of the unit, unauthorised interventions in the unit may lead to loss of warranty servicing claims
- This unit belongs to the product group with type Y connection. If the supply cord is damaged, it must be replaced by the manufacturer, its service centre, or similarly qualified person to avoid dangerous situations.
- The unit is classified as protection class 1 category of appliances in terms of protection against electric shock.
- The unit supply voltage of 1~230V/50-60Hz may not be modified in any way; otherwise, there is a risk of damaging the electrical elements of the unit.

3.3.2. Connection to Mains

- The unit is equipped with a separate strand-type supply cable (stranded wire). The stripping of the cables to the individual wires is 50 mm. The individual wires are equipped with crimped terminals.
- The supply cable length of 1 m may be shortened by a qualified person as needed.
- The individual wires are colour-coded
 - o brown/black – Phase conductor – L
 - o blue – Neutral conductor – N
 - o green-yellow – Protective conductor – PE

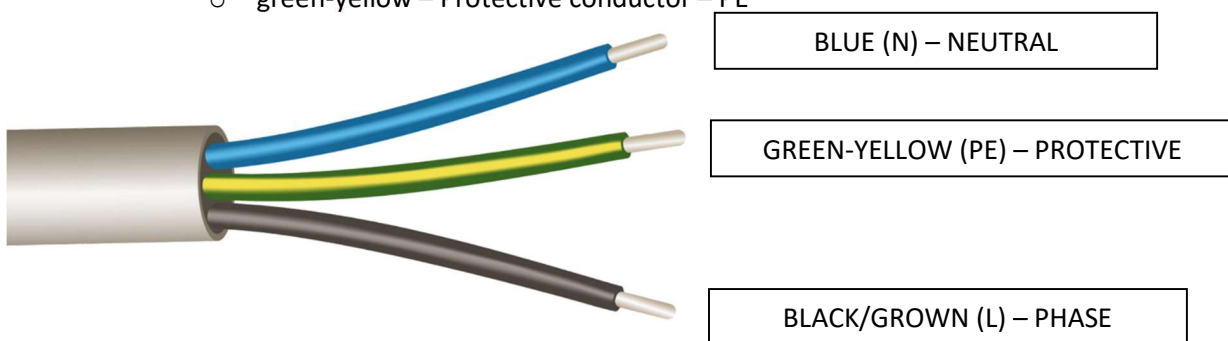

Fig. 22

3.3.2.1. Connection of the Unit to the Wiring Box

- The power supply cable is prepared by the manufacturer for connection to the wiring box.
- Use adequate connecting elements (e.g. terminal plates, spring terminals, etc.) to connect the power supply cable to the mains.
- **Installation of the power supply cable in the wiring box and connection to the mains must be carried out by a qualified person who has a valid authorisation for this activity and knowledge of the relevant standards and directives in the given country.**



3.3.2.2. Connecting the Unit to the Electrical Outlet

- The supply cable can be equipped with a fork with a protective wire (pin) – not included in the delivery.
- **Connection – installation of a plug on the supply cable must be performed by a qualified person who has a valid authorisation for this activity and knowledge of the relevant standards and directives in the given country.**



3.3.2.3. Recommended Xhouse unit protection

Unit type		Circuit breaker capacity	Number of phases x voltage
Xhouse 300	XH2-30-ECS0HRXxx-0A0	10 A	1x230V
	XH2-30-ECS0HRPxx-0A0		
	XH2-30-ECS0HRXxx-1A0		
	XH2-30-ECS0HRPxx-1A0		

Tab.17

3.3.3. Display of electrical parameters

- all the unit's electrical parameters are provided on the serial plate

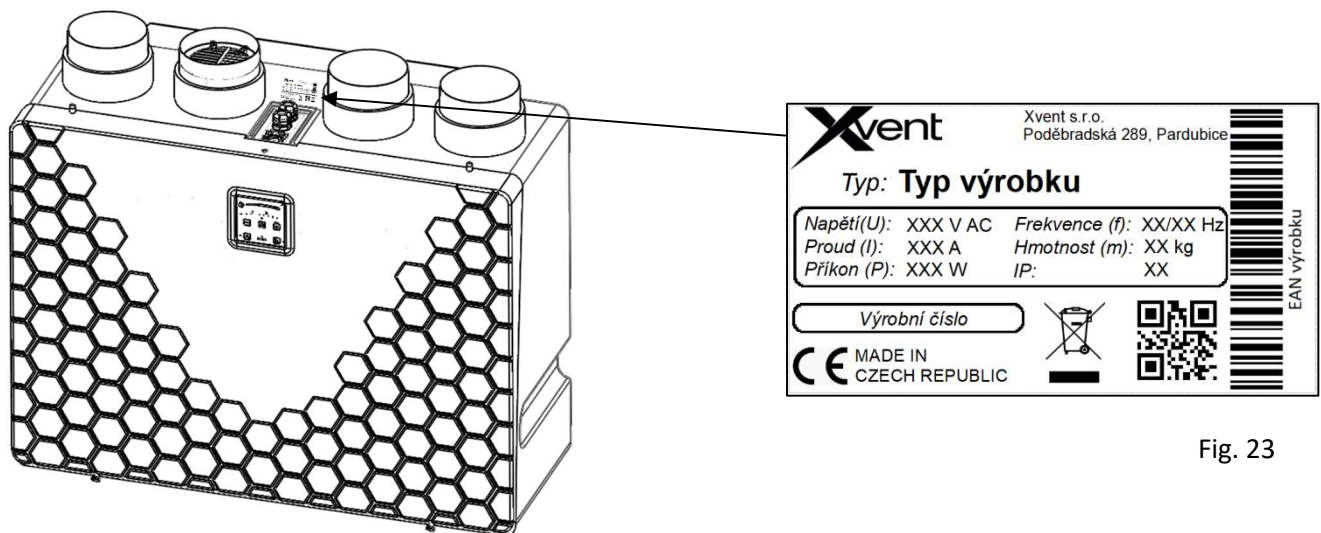

Fig. 23

4. Regulation

4.1. General Information – Safety

- There is no need to connect anything else to the unit for the correct operation of the unit (in the manual regime). It is therefore ready for immediate use after installation on the wall. To operate in the automatic regime, you must connect the CO₂ (NL-ECO-CO₂) or RH (NL-ECO-RH) air quality sensor accessory.

4.2. Electrical Accessories to the Xhouse Unit



- **Before connecting electrical accessories, always switch off the unit on the controller and with the main switch (position 16).**

4.2.1. Connecting Electrical Accessories

- Connect the electrical accessories in the control box.
 - o Loosen the securing screws of the design cover and remove it.
 - o Unscrew the locking screw of the control box M6x20.
 - o Loosen the 2x M6x20 bolt on the upper clamping rail.
 - o Remove the cover plate of the control box.
 - o Using the fabric strap, partially pull the control box out of the unit body. The control box can be pulled out only partially to allow access to the connecting periphery.
 - o Spring terminals with manual wire locking are used to connect the individual components. A strand-type conductor (stranded wire) and a solid conductor (wire) in the cross-section range from 0.5 to 1.5 mm² can be installed in the terminals. Before inserting the wire into the terminals, first press the locking orange button. Then retract the wire, release the lock, and

slightly pull it out of the terminal to verify that the wire is properly secured. If the wire needs to be removed from the terminal, the procedure is the same.

a) Loosen the locking screws of the design cover - remove the cover

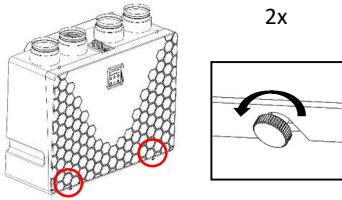

Fig. 24

b) Unscrew the locking screw of the control box

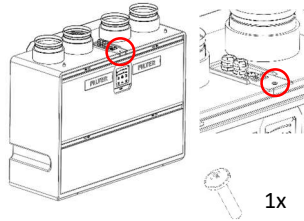

Fig. 25

c) Unscrew the 1x M6x20 screw on the sealing plate

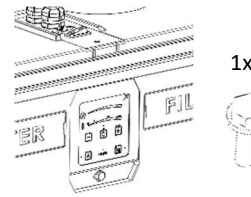

Fig. 26

d) Remove the cover plate of the control box

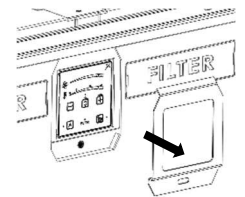

Fig. 27

e) Using the fabric strap, partially pull the control box out of the unit body. The control box can be pulled out only partially to allow access to the connecting periphery.

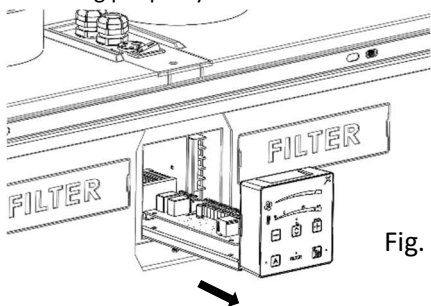

Fig. 28

f) Loosen the grommet nut to secure the supply cable

g) Slide the grommet plate out of the rear groove

h) Push the grommet plate to the side - into the longer groove
i) Pulling upwards, tip first one side of the sheet with the grommets and then the other. This will release the entire sheet metal with grommets.

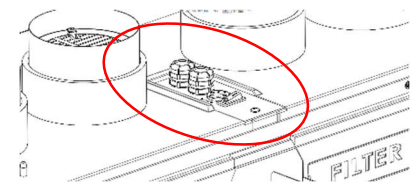

Fig. 29

- Pull the accessory and communication (modbus) cables into the unit through the prepared grommets in the upper part of the fitting between the sockets.
- Use the second free screw grommet to connect the communication cable for modbus control of the unit. It is recommended to pull the connector of the communication cable through the nut of the grommet first and then through the rest of the grommet.
- Use the membrane multi-pass for connecting the accessories. Always choose the individual penetrations according to the size of the cable you will use to connect the accessories.

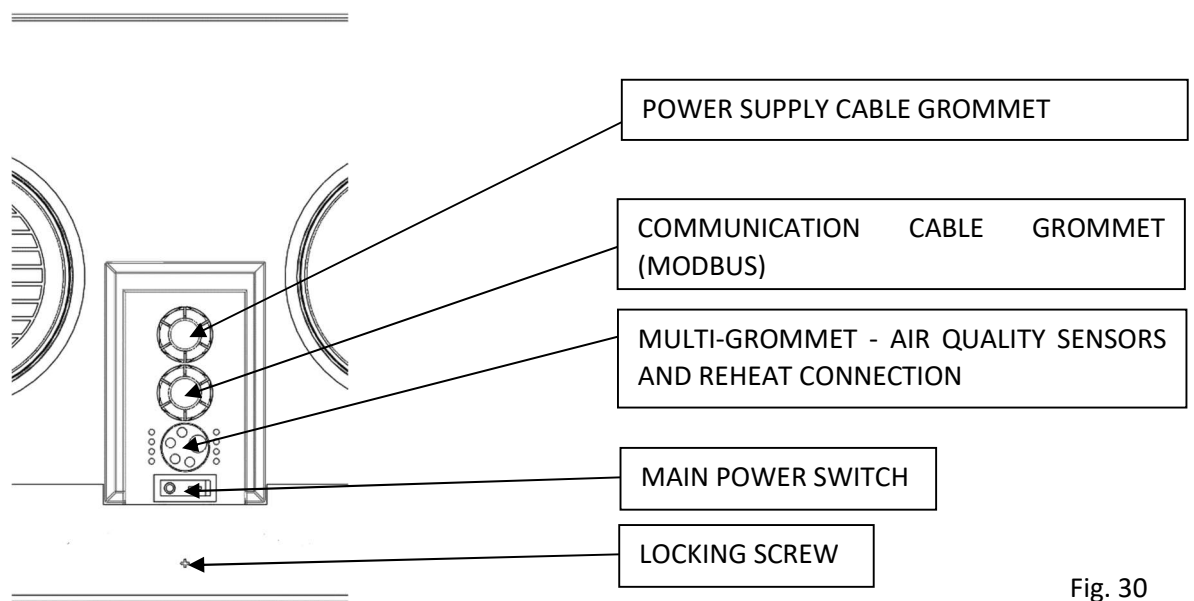

Fig. 30

If better access to the grommets is required, proceed as follows:

- Unscrew the locking self-tapping screw $\varnothing 3.5 \times 19$
- Loosen the grommet nut to secure the supply cable
- Slide the grommet plate out of the rear groove
- Push the sheet metal with the grommets to the side - into the longer groove
- Pull upwards to tip first one side of the sheet with the grommets and then the other. This will release the entire sheet metal with grommets.



- **The optimum cross-section of the conductor must be selected according to the actual length of the conductor route; however, the maximum diameter of the conductor may be 1.5 mm².**
- **All the wires shall be connected to terminals with adequate force to prevent damage to them or damage to the electrical board. The insulation stripping on the individual conductors must be 10 mm. For strand wires, the terminal must be crimped (socket).**



- **The regulation is normally integrated into the body of the unit and in any case must not be handled in any other way than as specified in this manual.**
- Location of terminals in the control unit for connection of the electrical accessories

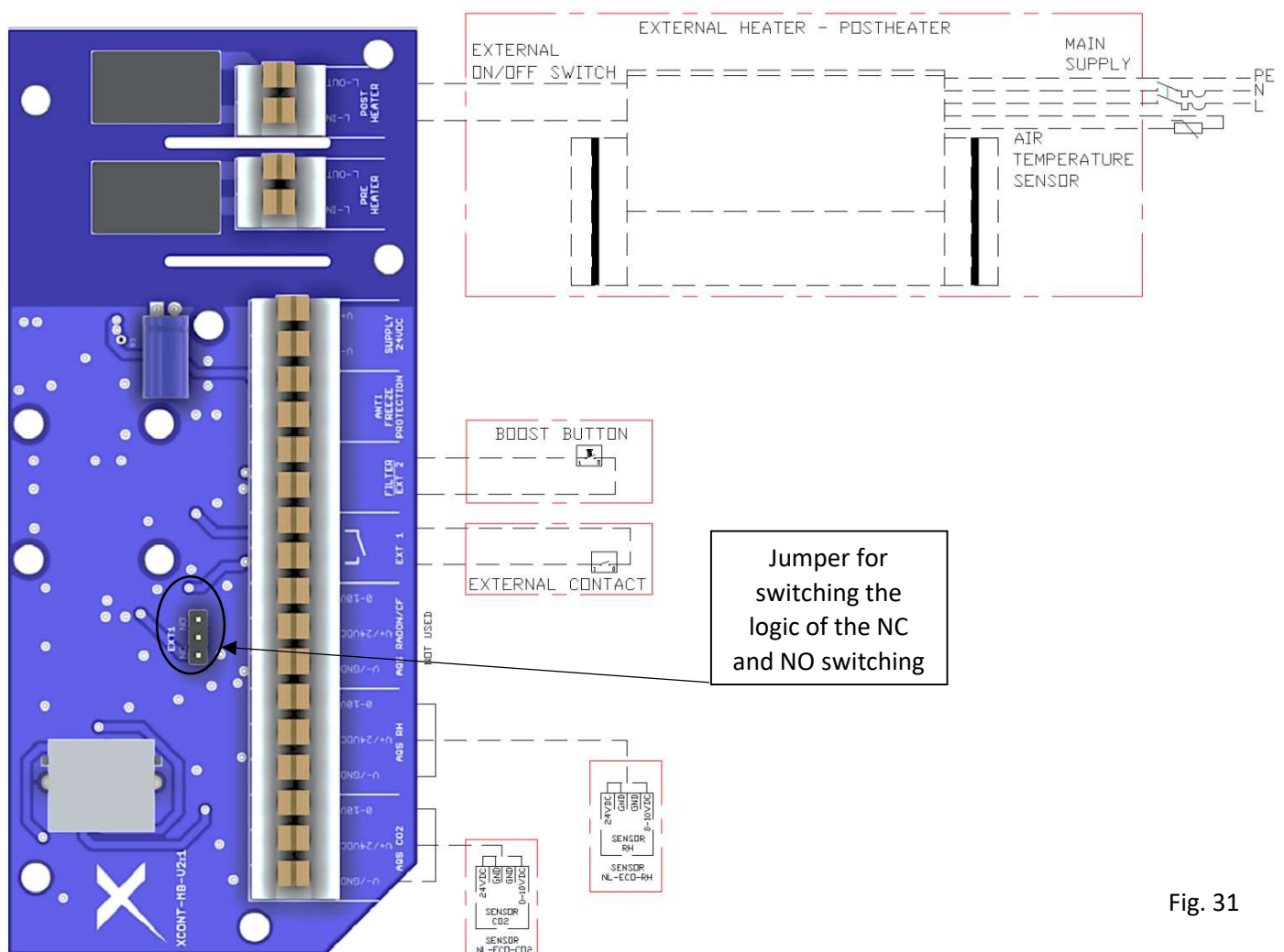

Fig. 31

4.2.2. Connection of the CO2 (NL-ECO-CO2) and RH (NL-ECO-RH) sensors - AQS sensors (AQS CO2; AQS RH))

- It is possible to connect 2x AQS sensors (1xCO2 and 1xRH) to the unit, which are used to measure the CO2 and RH concentration in the air at the place of sensor installation. Thanks to the sensors, it is possible to operate the automatic regime of the unit, which automatically controls the operation and air output of the unit according to the actual demand in the space where the sensors are installed. This method of control is also the most efficient in terms of operating economy - it is ventilated only as the need arises.

- **Technical parameters of the AQS sensors for connection to the unit**

- o 24 VDC sensor power supply
- o 0- 10VDC analog output
- o Max. sensor power consumption 5 W
- o Analog sensor input resistance 100kΩ

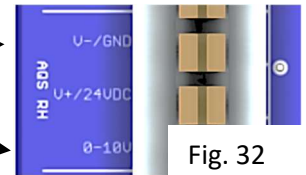

- **The power supply GND is shared with the GND of the analog input. If the connection is not carried out correctly, there is a risk of destroying the control board**

4.2.2.1. Connecting multiple AQS sensors

- Connecting more sensors than 1x CO₂ and 1x RH is possible using the “PRO-SUM-08” accessory.
- With this accessory, you can connect up to 8 sensors of one variable to one input on the control board (1 pc “PRO-SUM-08” = 8 pcs CO₂; 1 pc “PRO-SUM-08” = 8 pcs RH)
- Only sensors from one variable must be connected to one “PRO-SUM-08” accessory.

4.2.2.2. Unit functionality after connection of the AQS sensors

- If you wish to control the unit using the AQS sensors, activate the automatic regime function – button 4.
- The unit responds by continually controlling the need for real-time ventilation triggered by sensors:
 - o When the concentration of the monitored substances is reached, ventilation shall be switched on with the minimum flow rate:
 - CO₂ – 800 ppm,
 - RH – 65%.
 - o If the reduction of the concentration of the monitored substances in the room is not achieved, the unit controller increases the flow up to the maximum flow value set by the user.
 - o The unit controller will start to decrease the flow rate continuously again while reducing the concentration.
 - o The aim of the regulation – ventilation, is to find the ideal degree of ventilation (flow rate) depending on the concentration of the monitored substance in the ventilation room. For this reason, the unit may ventilate for a long time until it reaches safe limits of concentration or complete ventilation of the substance being monitored.
 - o When the concentration is reduced to a specified value, ventilation is switched off and the unit is switched to the standby mode:
 - CO₂ – 700 ppm,
 - RH – 60%.
- If there is a requirement for ventilation from several sensors, the controller gives priority to a sensor with a higher ventilation requirement.
- The AQS sensor ventilation switching level settings can be changed in the parent BMS (Modbus RTU).

4.2.3. External Contact Connection – EXT 1

- Unit control allows for connection of external contact for remote switching on and off of the unit (remote control ON/OFF).
- External contact is designed as potential-free and can be switched on e.g.:
 - o Using magnetic door contact (a contact used in security systems). The contact can be installed, for example, on the window. When the window is opened, the unit stops, and then restarts when the window is closed.
 - o Using a remote switch. In the facility, the electrical appliances are switched off by one button (the total stop system). The unit may be included in this system via this contact.
 - o Using a time relay. The unit may be switched on/off by a time relay located in the switchboard.

4.2.3.1. Technical Parameters of External Contact EXT1

- Switching voltage 24 VDC / 5 mA.
- The contact can change the switching logic by switching the jumper to NC or NO switching logic (factory setting)

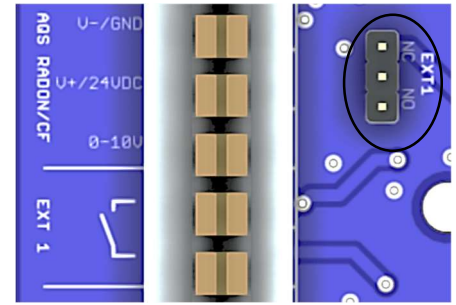
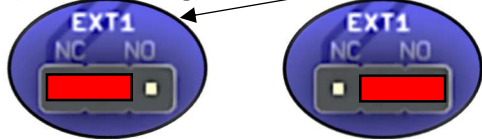

Fig. 33

4.2.3.2. Functionality of the Unit when Controlled by External Contact EXT1

- External contact switches the unit on and off (the same functionality as on the ON/OFF button controller) with logical termination or activation of all running processes at the time of switching off, on.
- If the unit is switched on/off by an external contact, it can be switched off/on by the controller on the unit.
- An example of the external contact functioning – a timer is used as an external contact:
 - EXT1 activates the unit at the given time (in the morning) – the unit operates according to the user settings,
 - during operation, the unit is switched off by the controller on the unit – the unit switches off,
 - EXT1 switches the unit off at a given time (in the evening) – the unit remains switched off,
 - EXT1 activates the unit at the given time (the following morning) – the unit works according to the user settings.



- **If you want to prevent control of the unit by unauthorised persons and you want to control the unit by external contact, we recommend that after setting the unit parameters, you activate a child lock, which prevents access to unauthorised persons (the unit cannot be switched off on the unit controller). This ensures that the unit is switched on/off only via an external switch.**

4.2.4. External Contact Connection – BOOST (EXT2/FILTER)

- The unit control allows the connection of an external button (damper switch with automatic damper return - e.g.: bell button with return spring) to start the shock ventilation regime for a set period of time - BOOST (hereinafter referred to as BOOST)
- The BOOST regime is designed for shock ventilation for a certain period of time in rooms with an immediate need for ventilation e.g.: bathroom, toilet etc..
- The BOOST regime is indicated on the unit's controller by flashing the 8LED diode



4.2.4.1. Technical Parameters of External Contact - BOOST

- The external contact is designed as potential-free
- Switched voltage 24 VDC / 5 mA.

4.2.4.2. BOOST regime functionality

- When the button (damper switch with automatic damper return) is pressed, the BOOST regime is activated
 - The BOOST regime is activated and the unit starts at the set air output and run time.
 - After the set BOOST regime run time is over, the unit returns to its previous regime.
- If you wish to exit BOOST regime before the set run time.
 - Hold the button for approx. 2 s.
 - The BOOST regime is automatically ended, and the unit returns to its previous regime.
- BOOST regime factory setting:
 - Air output in the BOOST regime - max air output of the unit
 - Duration of the BOOST regime - 1 min



Fig. 34



- The air output and duration of the BOOST regime is adjustable in the customer menu, see chapter 5.5.
- If necessary, it is also possible to start the BOOST regime directly at the unit controller, see chapter 5.4.2.

4.2.5. Connection of the unit to the parent BMS system using the Modbus RTU protocol

- Unit equipped with the possibility of connection to a higher-level BMS system (hereinafter referred to as BMS).
- The connection of the unit to the parent BMS must be carried out by a competent, knowledgeable person.
- The connection of the unit to the BMS must always be made using the "XCONT-HUB" accessory. Addressed by the separate "XCONT-HUB" accessory manual
- The connection cable (included in the "XCONT-HUB" package) between the controller and the "XCONT-HUB" accessory is connected to the controller, which is located in the lid of the unit.
- Insert the connection cable into the controller according to chapter 4.2.1.
- Plug the connection cable into the RJ connector marked BMS-RS485



Fig. 35

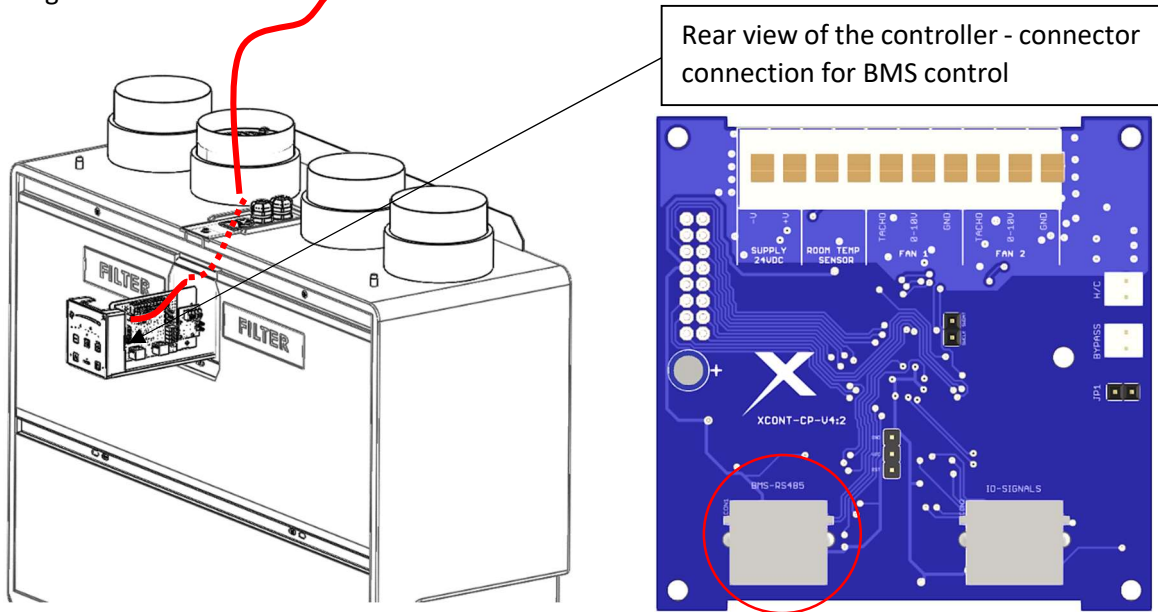

- Communication of the unit with the parent BMS system is solved by the Modbus RTU communication protocol. Protocol description is addressed in the separate user manual "D-502-xxx-Vxxx-xxx-MN-CENTRAL-MODBUS"

4.2.6. Connecting an external electric heater - (POSTHEATER)

- The unit can be connected to an external electric heater (hereinafter referred to as a heater) with the maximum output of 1,500 W, voltage 1 x 230 V.
- The unit switches only the supply phase - potential (L-IN) to the heater (L-OUT) in the logic:
 - o If the unit is ventilating, the phase is switched - the potential is switched
 - o If the unit is stationary, the switched phase - potential is open
 - o If the unit is ventilating but the ventilation request is terminated (AQS control - automatic regime).
 - The unit disconnects the switched phase
 - The power of the unit's fans is reduced to the minimum and the after-cooling regime runs for 3 min
 - The after-cooling regime is indicated by a flashing LED on the controller above the ON/OFF button
- The unit's control cannot detect the presence of an external heater, so it assumes it is always connected. The result is that whenever the fans are switched off (either by user request or AQS sensors), the after-cooling function is triggered.
- We recommend using a heater with a channel sensor (for temperature control) and control via an external contact from the unit



Fig. 36



- The supply cabling for the heater must be a separate supply including the switched phase controlled by the unit, under no circumstances must the heater be powered from the unit.
- Sample wiring diagram:

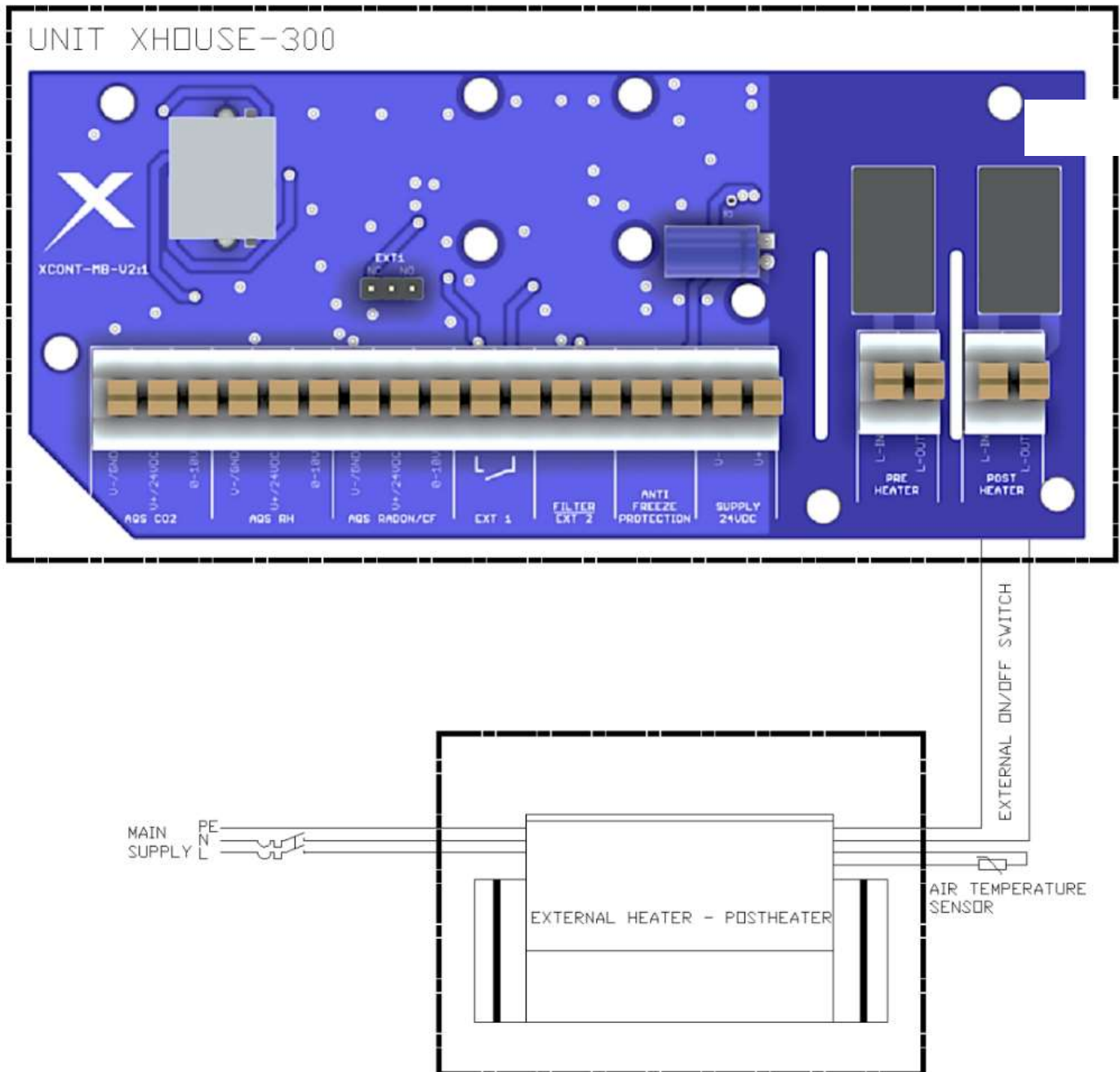

Fig. 37



- Install the heater - reheater according to the heater manufacturer's instructions e.g.: flow direction, distance from the unit, heater position, distance of temperature sensor from the heater etc...
- If the heater manufacturer requires a minimum line velocity for proper heater operation, this must be addressed by a separate component (e.g.: differential pressure sensor). Under no circumstances shall the unit be used for this purpose.
- In no event shall the manufacturer of the unit be liable for improper installation, malfunction or damage caused by the heater.

4.3. Block diagram of the Xhouse unit wiring

- Right version A (eg: XH2-030-ECS0HRPAS-1A0)

Fig. 38

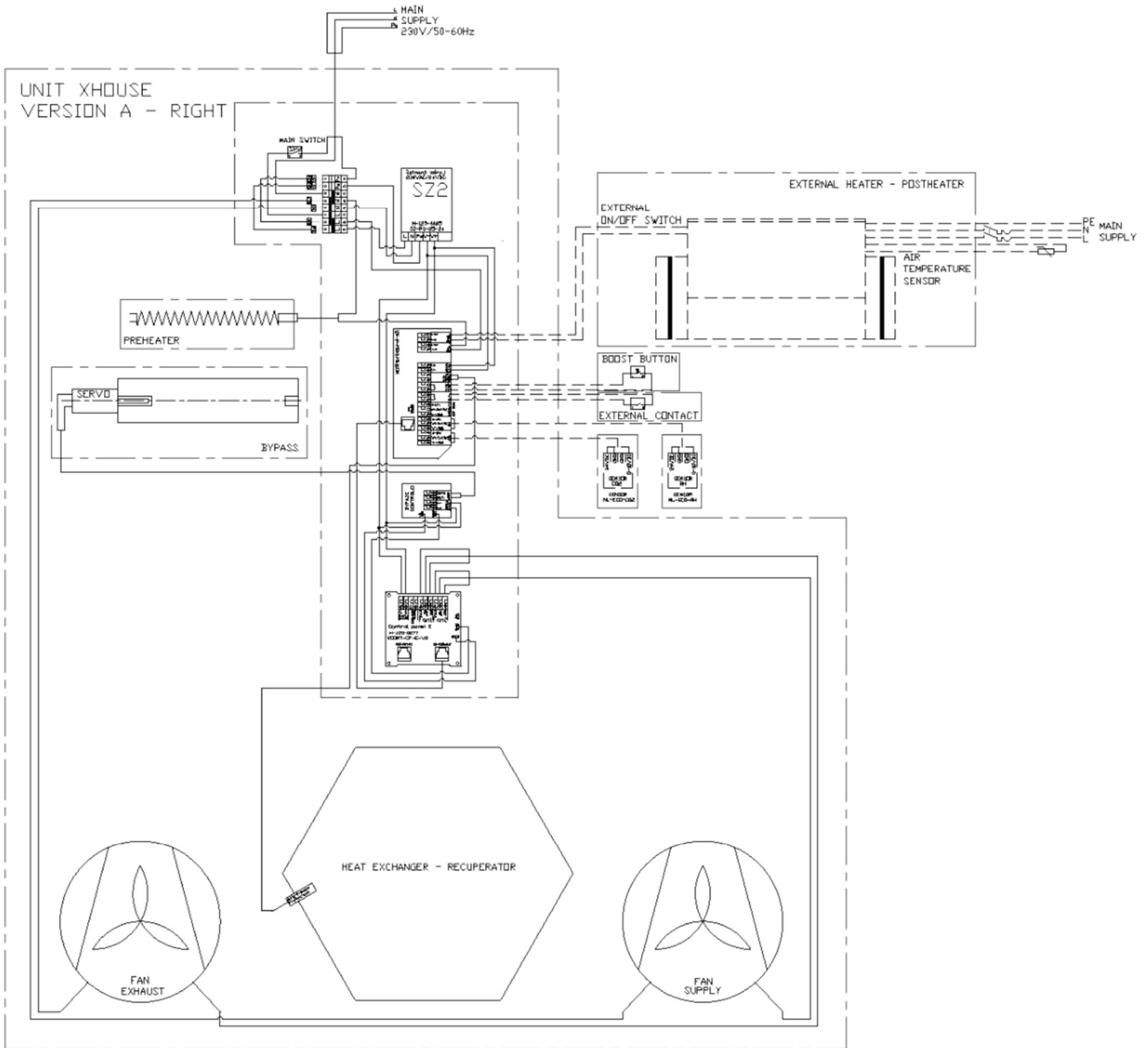

- Left version B (eg: XH2-030-ECS0HRPBS-1A0)

Fig. 39

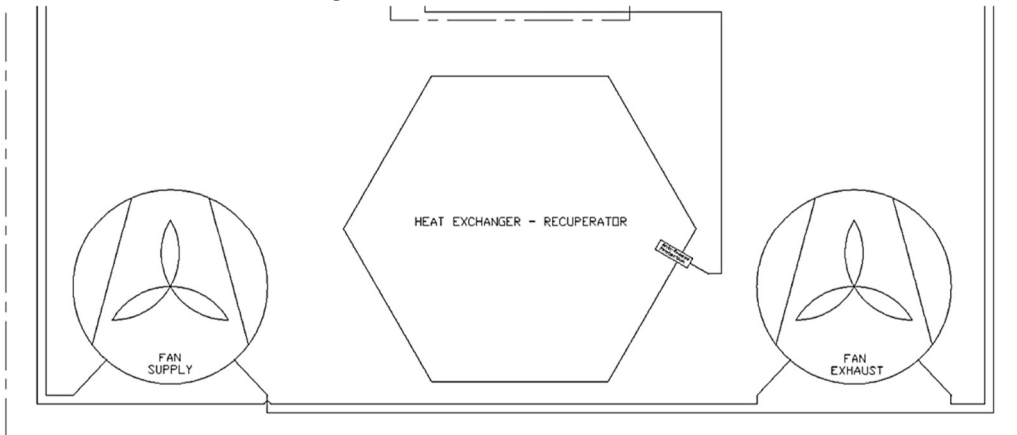

5. Commissioning

5.1. Prior to first startup, check:



- that all the installation work has been duly completed as indicated in Section 3,
- whether the power supply cable of the unit is properly connected to the mains,
- whether the connected electrical accessories are correctly wired,
- whether the condensation trap is watered, and the condensate outlet is connected to the sewer system,
- whether the unit contains clean filters.

5.2. Activation – Basic Unit Commissioning



- **The basic unit commissioning is used to verify the functionality of the unit after completion of the installation.**

Further options and details on unit settings are provided in the following Sections.

1. Switch the main switch from position 0 (OFF) to position 1 (ON) and wait until:
 - All the LEDs on the controller flash 3 times.
 - All the status LEDs flash.
 - The LEDs stop flashing - controller is loaded - you can continue

} Controller loading - can take up to 25 s.

The controller is loaded only when power is connected to the unit.

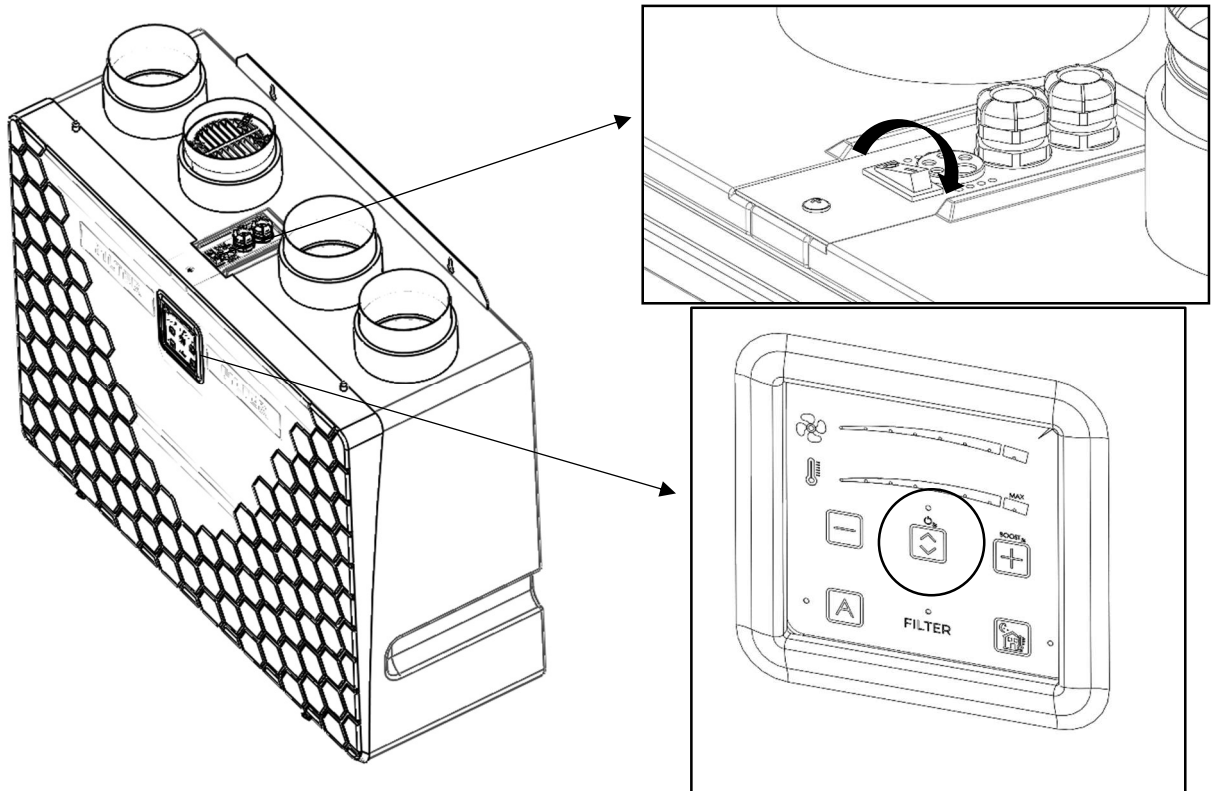

Fig. 40



2. Hold down the ON/OFF button for approx. 3 s until the blue status LED above it lights up. Unit is switched on
3. The unit is factory set to 4th ventilation level, which is used to verify the basic functionality of the unit.
4. Check the unit operation - for example: by hearing,
5. The unit is operational.
6. Now, you can perform further unit settings according to your requirements.



If you have already connected the AQS air quality sensors when you first start the unit, the automatic regime LED will flash - sensor calibration is in progress (approx. 5 s). The fans can take up to 20 s to start up from idle.

5.3. Controller Operating Regimes

- The controller operates in 3 display regimes.

5.3.1. Sleep Regime – Regular Operating Regime

- Only the operating state is displayed – the unit is on and the LED on/off of the unit is on (button 2). The unit is fully functional, running according to user settings.

5.3.2. Control Regime – 1 click

- When any button is clicked, the active functions and settings of the unit (ventilation power) are displayed on the controller. The display is lit for approx. 4 s, then the controller returns to the sleep regime.
- The functions that can be started from this regime are listed in Table 17. Description of the control functions of the Xhouse units.

5.3.3. Unit Setting Regime – 2 clicks

- The setting or activation of some functions is only possible from this regime.
- The setting regime is activated by clicking on the button, for which the function is to be changed. The plus and minus button is for activation - power setting, ventilation (flashing LED in the fan pictogram)
- The functions that can be started from this regime are listed in Table 17. Description of the control functions of the Xhouse units.

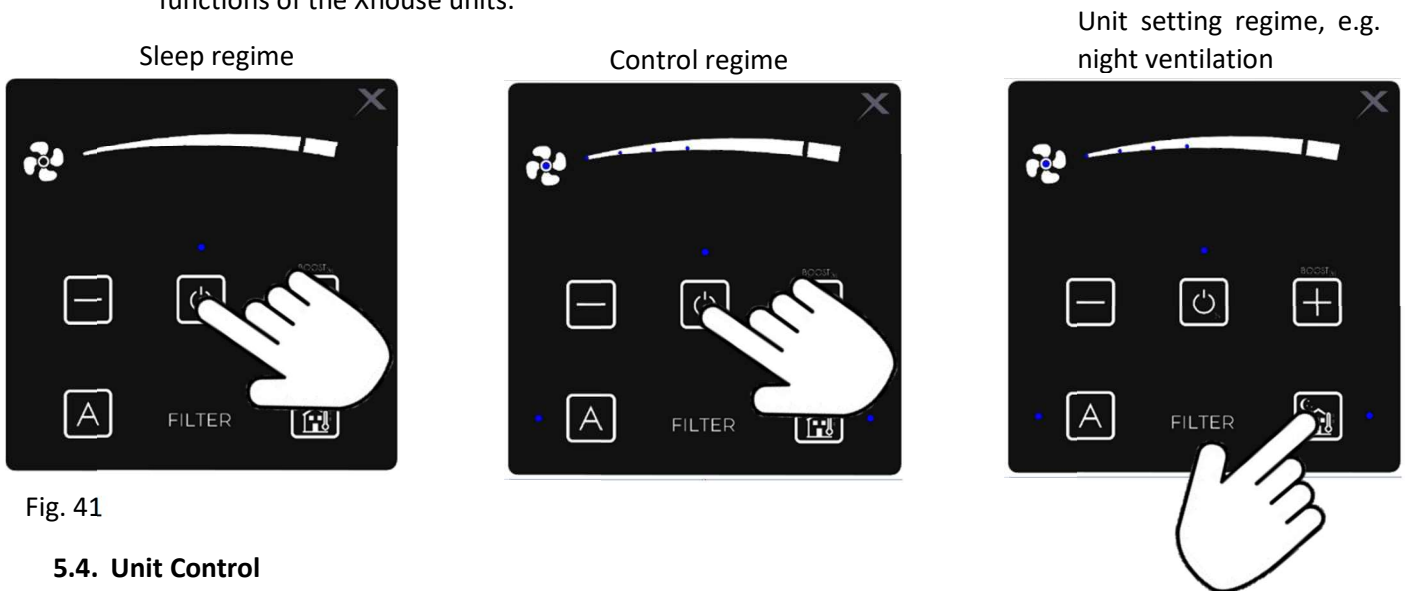

Fig. 41

5.4. Unit Control

5.4.1. Control panel – controller

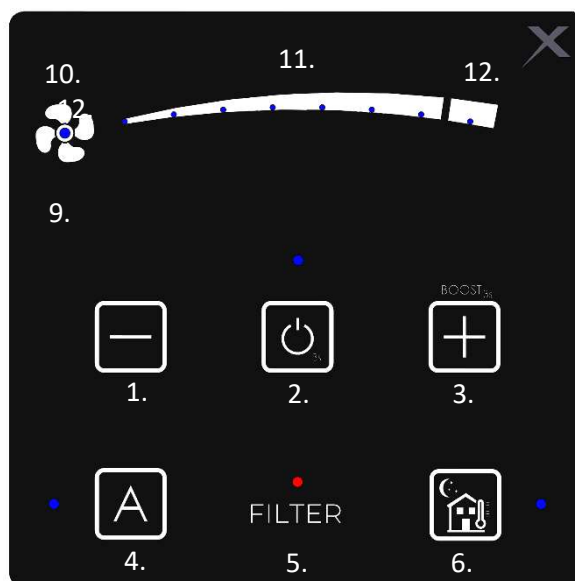

Fig. 42

5.4.2. Description of the functions of the buttons and regulation

Control description number	Symbol	Button/Indication	Button description	Active in mode / number of Settings			Function	Note
				Dormant 0x	Control 1x	2x		
1.		Button	Reduction of ventilation output	✗	✗	✓	- Switches from the control regime to the ventilation output setting regime - Press the button to reduce the desired level by one step on the ventilation output setting scale	
2.		Button	Unit switching on (signalling)/switching off ON/OFF	✓	✓	✗	- By holding the button for 3 seconds, switch the unit on (LED lights up) or off - if the LED flashes after the unit is switched off, the heating is cooled down. Once finished, it will turn off	
3.		Toggle function button	Start of intensive ventilation - BOOST Increasing the level of ventilation output	✗	✓	✗	- Press the button for 3sec to start intensive ventilation for 1 min. To switch it off before 10 minutes pass, press the button again for 3 seconds, and the ventilation returns to the pre-start regime. - Switches from control regime to the ventilation output setting regime - Press the button to increase the demand on the ventilation output setting scale	- The function start indication is flashing diode 12. - The air output for intensive ventilation and the running time in the boost regime is set in the customer menu 5.5.
4.		Status indication button	Switching between automatic mode (signalling) and manual mode	✗	✓	✓	- The factory setting is the manual regime, request for continuous ventilation - ventilation is operated at user request, ignores requests from AQS sensors - indicator light is not lit - Press to activate automatic mode, ventilation on demand - ventilation is operated according to the AQS sensor requests - the light is on	- If you activate the automatic regime, and the light at the button flashes 3 times and returns to the manual regime - no AQS sensors are attached
5.		Status indication	Filter clogged indication	✗	✗	✗	- The clogged filter indication is triggered after approx. 6 months of unit operation (only if the unit is ventilating). - The indication is expressed by a flashing red LED.	- Replace and reset the filter according to Section 6.
6.		Double-function and status indication button	Night cooling - on (signalling)/off Child lock	✗	✓	✓	- Press the button to start the night cooling function. Night cooling is used to cool the ventilated area in the summer with night cold air. The function is active for 8 hours from pressing the button. - The intensity of the supplied air can be changed even when the function is activated. When the function is completed, the values return to the settings before the function started. - protection against manipulation by unauthorised persons. It is activated/deactivated by pressing the button for more than 6 sec. Activation/deactivation is indicated by 3 flashes of all the status LEDs	- It is recommended to activate the function after 10 p.m. During the summer months, the air is coldest around 5 a.m. - When attempting to change the parameters during the activated function, all the status LEDs flash once
10.		Status indication	Ventilation operation status diode	✗	✓	✓	- In the control regime, the diode is lit - unit is ventilating - In the setting regime, the diode flashes - you are in the required ventilation output setting regime - Ventilation can be switched off. In the setting mode, reduce the output (button 1) until the last diode on the range turns off.	You can use the fan shutdown e.g.: in the summer - you do not wish to ventilate normally, but you wish to turn on night cooling to cool down the building that the unit serves

5.4.3. Description of the ventilation power setting range

Tab. 19

Control description number	Symbol	Display description	Note
11.		Indication of 7 ventilation levels. The LEDs are switched on and off gradually, as required by the user	The setting values are provided in Tab.19.
12.		Signalling by flashing LED for 1 min - intensive ventilation function started - can be adjusted in the customer menu	If the intensive ventilation function is activated, the entire range for setting the ventilation level is also lit.

- Unit output settings

Tab. 20

Displayed LED on the controller range	Recuperation exchanger - HRV		Recuperation exchanger - ERV	
	Electronic bypass	Mechanical bypass	Electronic bypass	Mechanical bypass
	XH2-30-ECS0HRxxS-0A0	XH2-30-ECS0HRxxS-1A0	XH2-30-ECS0ERxxS-0A0	XH2-30-ECS0ERxxS-1A0
	m ³ /h*	m ³ /h*	m ³ /h*	m ³ /h*
1.	50	48	45	45
2.	70	73	73	73
3.	105	105	105	105
4.	145	145	145	145
5.	190	190	185	185
6.	235	235	235	235
7. - nominál - BOOST**	250	250	250	250

* Air outputs are given at the external pressure drop of 200 Pa per the nominal flow (stage 7)

** BOOST regime - maximum intense ventilation for a set period of time (ventilation intensity and ventilation time can be set in the customer menu)

5.4.4. Ventilation Output Settings

1. In the regular regime, double-click on button 1 or 2 or 3 to enter the settings regime – LED 10 flashes (fan pictogram).
 2. As long as LED 10 flashes (approx. 4 s), set the required degree of ventilation according to Table 19 or according to your request with buttons 1 or 3: If necessary, consult an HVAC professional for the correct ventilation performance setting.
 - o If you did not manage to complete the settings (LED 10 stopped flashing), repeat the procedure.
- After setting the request, the newly set value is automatically saved (approx. within 4 s) and the controller switches to the regular regime.

5.4.5. Display of the LED Indicated Statuses on the Controller

- The LED signalling on the controller is the same for all the unit types.

Status LED - fan - 10.
Blue
- shine - fan operation
- flashing - in the fan power setting mode

Blue LED status diode - automatic (AQS) / manual (depending on the user) - 4.
- shine - automatic mode ON (AQS)
- Flashing - reading a number
- Flashes 3 times and then goes out - no sensor

Blue LED range diode - ventilation level - 11; 12
- shine - shows the selected ventilation level
- LED 1; 2; 3; 4 flashing - supply fan failure
- LED 5; 6; 7; 8 flashing - exhaust fan failure
- LED 3; 4; 5; 6 flashing - "anti-freeze" sensor failure

Blue LED status diode - ON/OFF
- shine - the unit controller - ON
- flashes – cooling mode after switching off the control

Blue LED status diode - summer mode - 6.
- shine - function activated
- Flashes 3 times - function inactive - poor ambient conditions

Red LED status diode - filter clogging - 5.
- flashing - indicates filter clogging

Common functions for all the blue status diodes - 3 flashes for activation and deactivation of the "child lock" function
- 1 flash for indicating that the "child lock" function is active
- 3 flashes when starting the BOOST function - cannot be activated - low outdoor temperature

Fig. 43

5.4.6. Hidden Regulation Functions

- The control behaviour includes automatic processes that ensure optimal operation of the unit with emphasis on the maximum service life and efficiency of the operation. These processes are part of the manufacturer's factory setup and know-how. The user cannot change them. As a result of these automatic processes, the behaviour of the unit may be different from that assumed by the user.
- These are mainly automatic processes:
 - o unit preheating control – switches only when necessary,
 - o anti-freeze logics triggering – measures against recuperator freezing,
 - o minimum preheating, heating operation time – protective function,
 - o cooling after switching off pre-heating, heating – protective against overheating of the exchanger
 - o Unit control using AQS sensors - automatic functionality according to ventilation needs

5.4.7. Automatic Unit Control using AQS Sensors



- AQS sensors for sensing the CO₂ concentration in the room and RH humidity sensors can be connected to the unit using accessories, see chapter 4.2.2.
- After connecting the AQS sensors to the unit, activate the automatic regime function - button 4.
- The unit responds by continually controlling the need for real-time ventilation triggered by sensors:
 - o When the concentration of the monitored substances is reached, ventilation shall be switched on with the minimum flow rate:
 - CO₂ – 800 ppm,
 - RH – 65%.
 - o If the reduction of the concentration of the monitored substances in the room is not achieved, the unit controller increases the flow up to the maximum flow value set by the user.
 - o The unit controller will start to decrease the flow rate continuously again while reducing the concentration.
 - o The aim of the regulation – ventilation, is to find the ideal degree of ventilation (flow rate) depending on the concentration of the monitored substance in the ventilation room. For this reason, the unit may ventilate for a long time until it reaches safe limits of concentration or complete ventilation of the substance being monitored.
 - o When the concentration is reduced to a specified value, ventilation is switched off and the unit is switched to the standby mode:
 - CO₂ – 700 ppm,
 - RH – 60%.
 - o If there is a requirement for ventilation from several sensors, the controller gives priority to a sensor with a higher ventilation requirement.

5.5. Customer Menu

5.5.1. Service Menu Access

- The unit is connected to its power supply - the main switch is on (position I)
- The controller has been loaded - see chapter 5.2. – item 1)
- The controller is switched off - if necessary, switch it off (the ON/OFF button must not be lit or flashing - 2.) - the unit is switched off by the controller
- Press key 1. “reducing fan output level” for 6 s.
- After 6 s, the entire fan setting scale flashes once - you are in the customer menu.

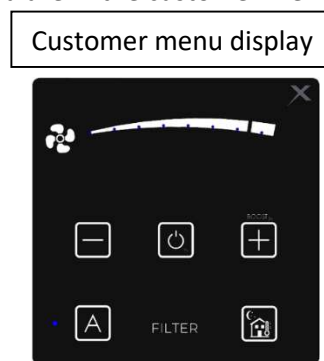
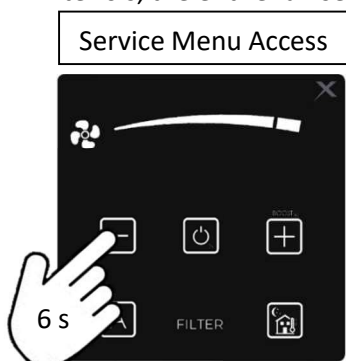

Fig. 44

- The automatic display time of the customer menu is 15 s from the last activity. After this time, the adjusted values are saved, and the controller is switched off. Repeat the previous steps to re-enter the customer menu.

5.5.2. Setting the air output for the BOOST regime - 1st screen

- After entering the customer menu, the air output setting scale 11; 12 (controller description number) immediately displays the set air output for the BOOST regime
 - o The BOOST regime factory setting is at maximum air output - all the LEDs are lit to indicate fan output
- The air output is adjusted using the button 1 (decrease) and button 3. (increase). The display on the scale is always two LEDs at a time

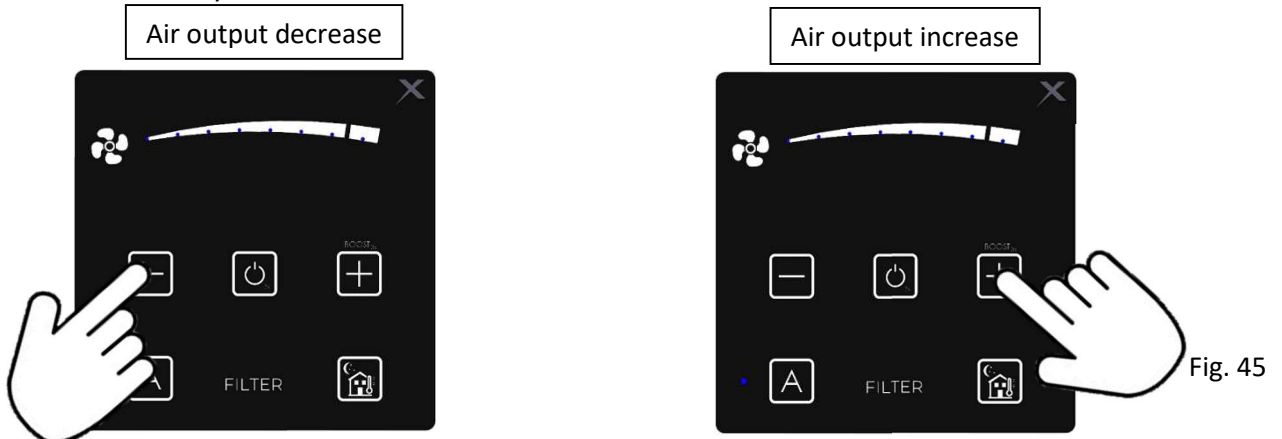

Fig. 45

- Air power setting level in the BOOST regime

Tab. 21

Recovery exchanger type	Bypass type	Unit type	Displayed LED on the controller range			
			1+2 m ³ /h*	3+4 m ³ /h*	5+6 m ³ /h*	7+8 m ³ /h*
HRV	Electronic	XH2-30-ECS0HRxxS-0A0	145	190	235	250
	Mechanical	XH2-30-ECS0HRxxS-1A0	145	190	235	250
ERV	Electronic	XH2-30-ECS0ERxxS-0A0	145	185	235	250
	Mechanical	XH2-30-ECS0ERxxS-1A0	145	185	235	250

* Air outputs are given at an external pressure drop of 150 Pa per the nominal flow rate

Highlighted values - factory settings

- To save the set values, leave the controller idle (approx. 15 s) until it switches off.

5.5.3. BOOST regime run time setting - 2nd screen



- After entering the customer menu, press button 4, where the LED lights up
- The LED at button 4 will flash - you are in the BOOST regime
- On the air output adjustment scale 11.; 12, there you will see the set time of the BOOST regime
 - o The factory setting is 1min - 1 and 2 LEDs are lit
- Set the running time using button 1 (decrease) and button 3. (increase).

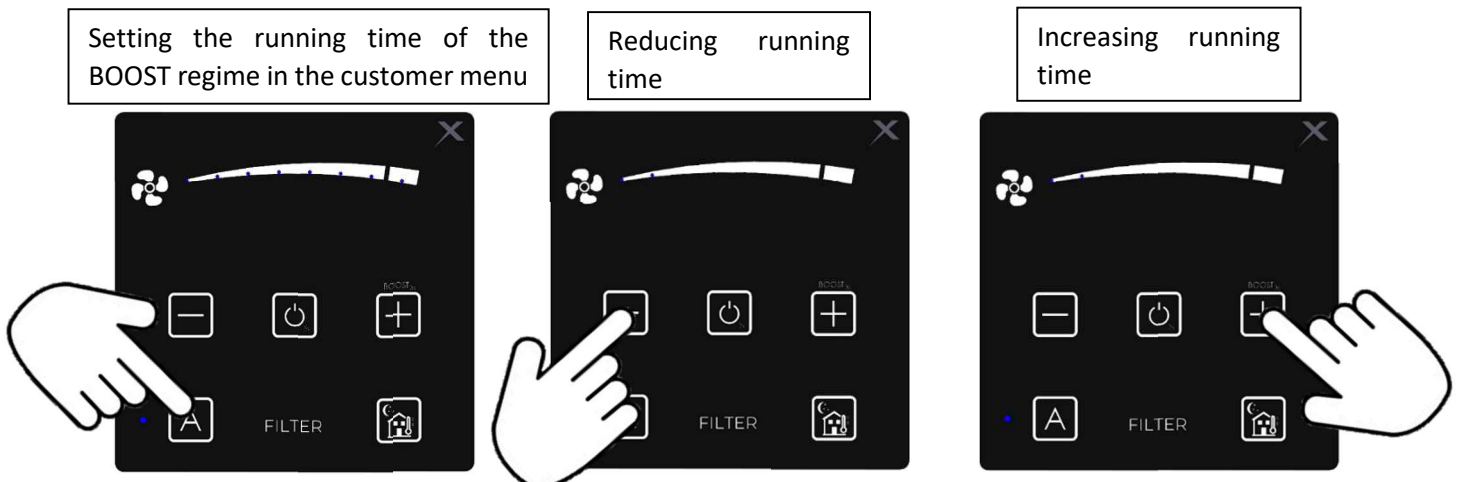

Fig. 46

- Options for setting the running time in the BOOST regime

Tab. 22

Displayed LED on the controller range	1.	2.	3.	4.
Running time in the BOOST regime	0,5 min	1 min	2 min	4 min
Displayed LED on the controller range	5.	6.	7.	8.
Running time in the BOOST regime	7 min	10 min	15 min	20 min

Highlighted value - factory setting



- **If the unit is connected to a parent BMS and the BOOST running time is set to a different time than can be set on the unit controller, the nearest LED to which the set time in the BMS is rounded flashes.**
- To save the set values, leave the controller idle (approx. 15 s) until it switches off.

5.5.4. Fan distribution setting - 3rd screen

- The fan distribution setting is used to increase the air output of the supply air. This means that the building served by the unit is pressurized (more air is supplied than exhausted).



- **Consult a specialist in the field of ventilation (designer) for the correct setting of the fan distribution (overpressure), and consult a chimney sweep if used in rooms with a fireplace.**
- **Incorrect fan distribution settings can result in reduced comfort in the building, improper operation of the unit and thus reduced unit life.**



- Press button 6 after you enter the customer menu.
- The LED next to button 6 will light up - you are in the BOOST running time setting regime
- On the air power setting scale 11.; 12, there you will see the fan distribution settings
 - o Factory setting is equal pressure - 0 fan distribution - 1 LED diode is lit
- Set the fan distribution with button 1 (decrease) and button 3. (increase).

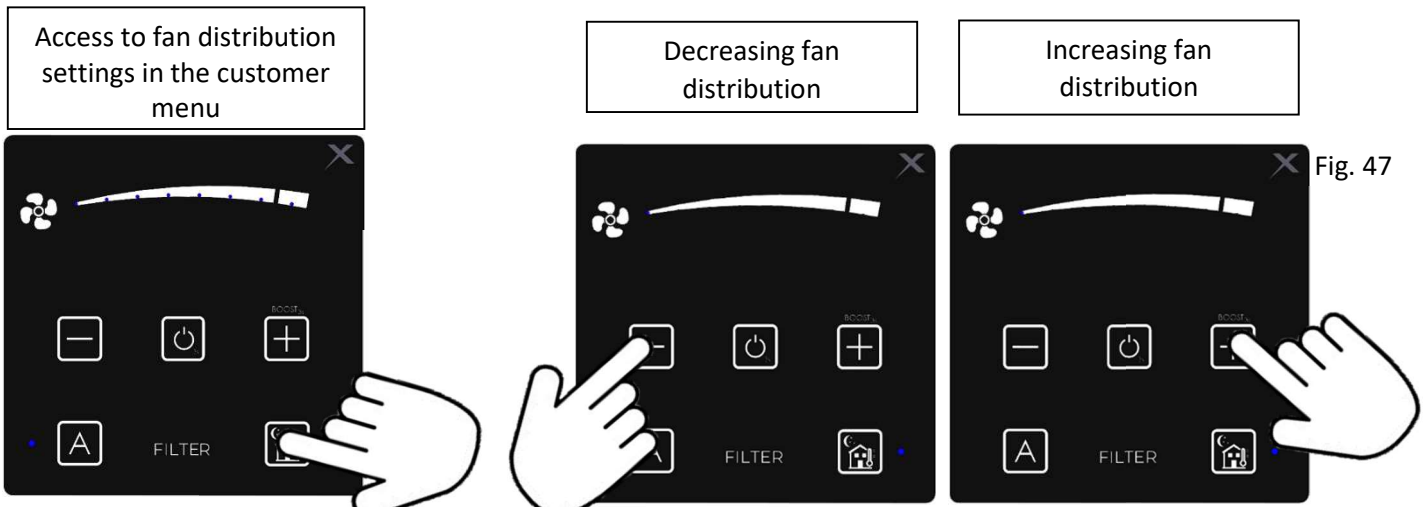

- Options for setting the fan distribution

Tab. 23

Displayed LED on the controller range	1.	2.	3.	4.
% fan distribution	0% - equal pressure	5 %	10 %	15 %
Displayed LED on the controller range	5.	6.	7.	8.
% fan distribution	20 %	25 %	30 %	35 %

Highlighted value - factory setting



- Press button 4 to return to the BOOST regime settings.
- To save the set values, leave the controller idle (approx. 15 s) until it switches off.

6. Replacing Filters

- Before starting any service work, the power supply must be switched off. **During the installation, the switch must be secured against being switched on again by an unauthorised person.**
- The unit is equipped with a filter clogging countdown for approx. 6 months (approx. 4400 hours). The countdown reads the unit's real operation.
- Filter clogging depends on the environment, in which the unit operates. Especially, on the dustiness of the surrounding air – the more dust particles are contained in the air, the sooner the filter box is clogged. Therefore when filter clogging is indicated, always consider replacing them.
- The filter replacement control is indicated on the control panel by a red flashing LED titled “filter” (position 5 on the controller).
- Before starting to replace filters, make sure you have new ones:
 - o Filter M5 XH-030-FILTER-M5
 - o Filter F7 XH-030-FILTER-F7

6.1. Filter Removal

- Loosen the M6x20 plastic screws on the front plastic design cover, slide it out of the unit and store them securely.
- Using the fabric straps, remove the plastic caps from the unit lid marked FILTER.
- Pull the filters, check them and or replace with a new filter

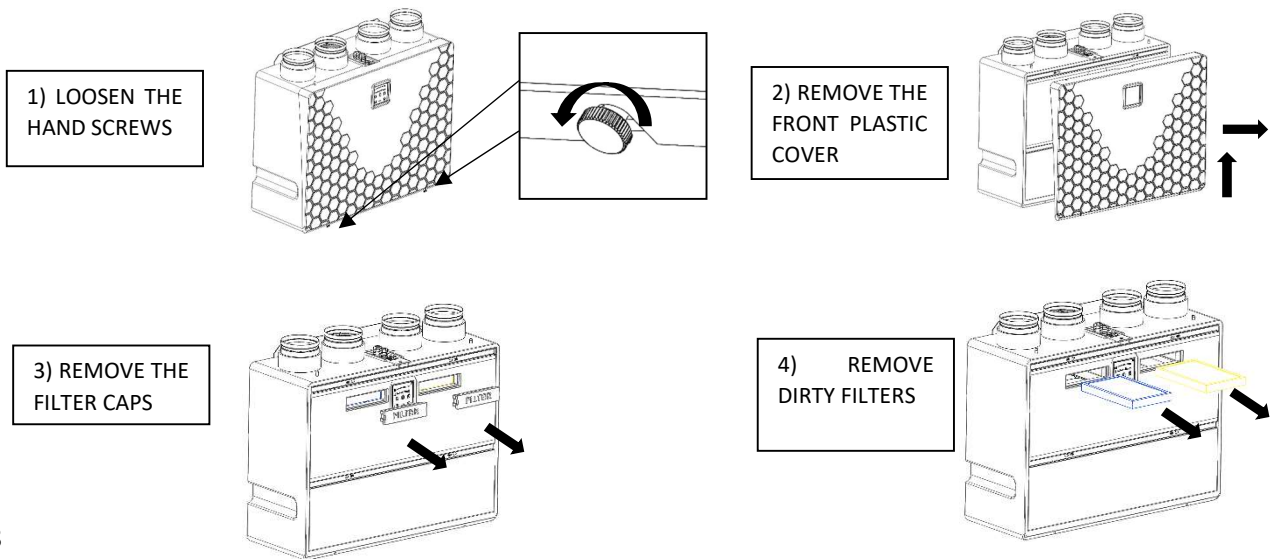

Fig. 48

6.2. Filter Inserting



Pay attention to the correct orientation of the filter before it is inserted into the unit with regard to the air flow

- Insert new filters into the unit.
- Align the filter holders so that they do not interfere with the installation of the plastic filter caps.
- Fit the filter caps into the unit lid so that they are flush with the unit lid.

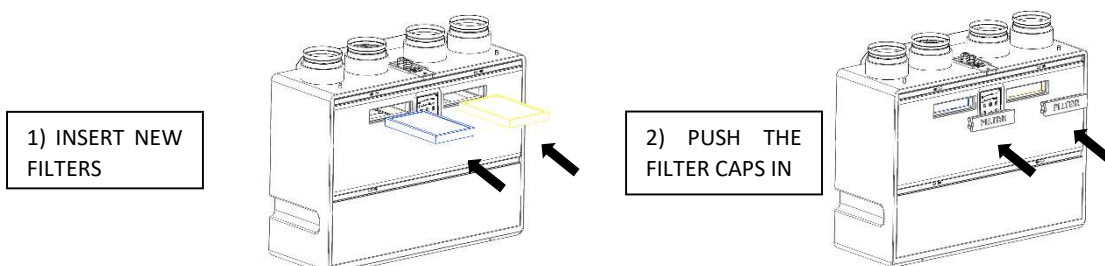

Fig. 49

- Hang a plastic design cover on the plastic spikes located in the unit body
- At the bottom of the unit, there secure the cover (2x M6x20 screws) with adequate force - by hand, so that the cover does not loosen spontaneously, but at the same time does not get destroyed - deformed.

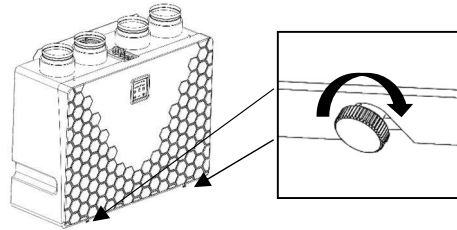

Fig. 50

6.3. Reset filter countdown

- Resetting the filter is always done after the red indicator light 5 is on. FILTER.
- Reset the filter in the normal operating state of the unit (sleeping or control regime):
 - o Press button 4 and button 6 at the same time.
 - o After approx. 4 s, red light 5 FILTER will go out. This will reset the timer and restart the fan running time.

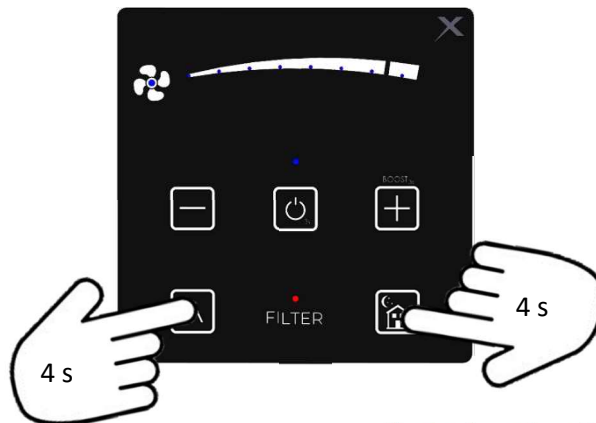

Fig. 51



- **If the filters are not properly replaced (cleaned), the functionality of the unit may be reduced.**
- **Never operate the unit without air filters, the recuperator may be damaged.**

7. Regular Maintenance and Cleaning of Xhouse Units



- **Before opening the unit during its maintenance and cleaning, the unit must be disconnected from the power supply**



- **Maintenance and cleaning must be performed at regular intervals; otherwise, the functionality of the unit may be impaired.**

- **Children may not perform cleaning maintenance without supervision.**
- **Compressed air, steam, solvents, aggressive chemicals, abrasive cleaning agents, or sharp items must not be used to clean the unit.**
- Perform maintenance and cleaning of the unit in regular cycles to ensure its hygienic operation. In the case of regular filter replacement (use the manufacturer's original filters) as indicated, the maintenance interval of the maximum of 2 years or at intervals determined by the relevant national regulations or practices must be observed.
- If the unit is not used for a longer period of time, it is necessary to switch off the power supply to the unit.
- Service work that is beyond the scope of routine maintenance may only be performed by an authorised service centre or the manufacturer.



- Regular maintenance must include:
 - o Visual inspection of the unit casing - Chapter 7.1.1.,
 - o Visual inspection of the power supply cable - Chapter 7.1.2.,
 - o Cleaning of the fan chambers and fans - Chapter 7.2.1.
 - o Visual inspection - cleaning of the pre-heater if it is available - Chapter 7.2.2.,
 - o Visual inspection and cleaning of the heat recovery exchanger - Chapter 7.2.3.,

- For cleaning the unit from coarse dirt or dust, use a vacuum cleaner or damp cloth with a common cleaning agent (e.g. soapy water).

7.1. Inspection - cleaning the exterior of the unit

- Externally inspect the unit over the entire surface of the unit casing with the plastic cover removed.
- To remove the plastic design cover, loosen the M6x20 plastic screws on the bottom of the unit. Slide the cover upwards and store it securely.

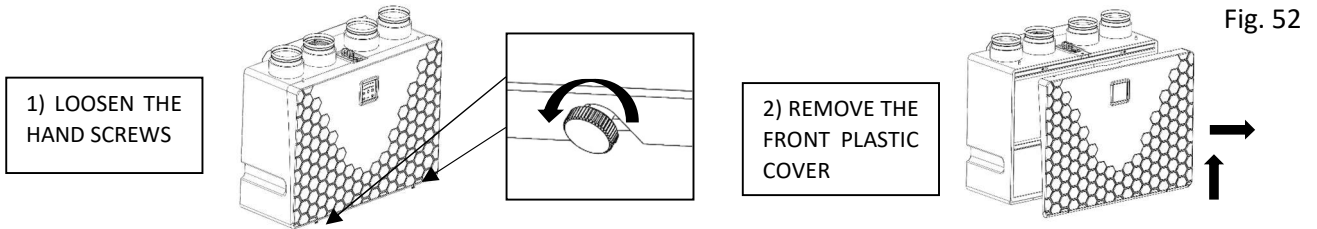

- Replace the cover using the reverse procedure. Tighten the screws by hand

7.1.1. Visual Inspection of the Unit Casing

- The unit can be cleaned on its entire surface.
- Visually inspect the outer casing of the unit for excessive soiling, damage:
 - o If the smooth surfaces of the casing are dirty, wipe them with a damp cloth with a common cleaning agent (e.g.: soapy water),

7.1.2. Visual Inspection of the Supply Cable

- Visually check that the supply cable is not damaged, loosen, or torn from the connecting peripherals.
- **In case of damage, consult with the person competent for this activity with the valid authorisation and knowledge of the relevant standards and directives.**



7.2. Inspection - Cleaning of the unit interior

- **Pay particular attention to the disassembly of the internal components of the unit. Improper disassembly may cause the unit to malfunction or limit its functions.**



- Remove the front plastic design cover - see chapter 7.1.
- Unscrew the 5x M6x25 screw securing the unit cover
- Unscrew the \varnothing 3.5x20 self-tapping screw securing the control cover plate
- Remove the filter caps using the fabric straps
- Remove the filters - see chapter 6.1.
- Remove the plastic cover using the holes of the filters
- Pull out the unit cover (position 5)

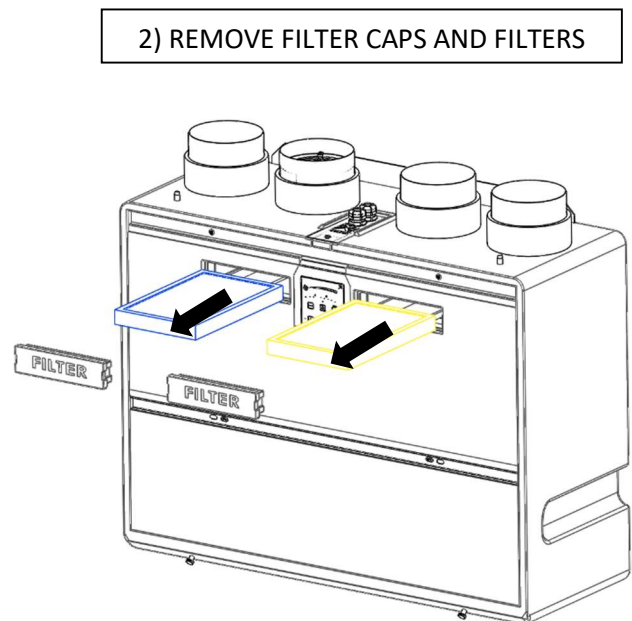
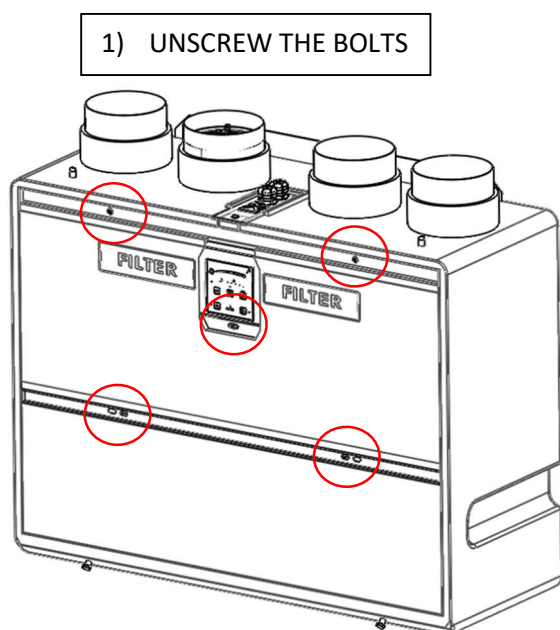

Fig. 53

Fig. 54

3) REMOVE THE UNIT LID

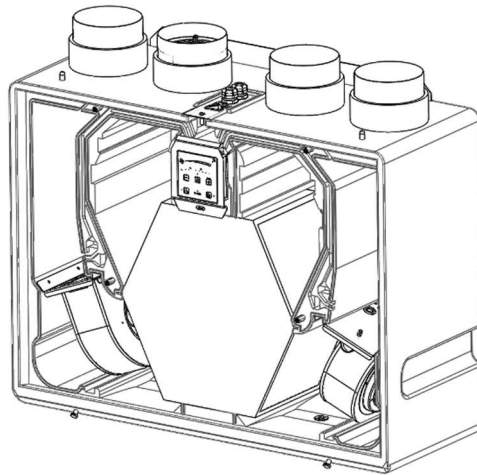

Fig. 55



- The following sub-categories of the instructions are consecutive actions to be followed in the order shown.

7.2.1. Cleaning the Fan Chamber and Fans

- Unscrew the 3 self-tapping screws securing the fan beam to the unit body.

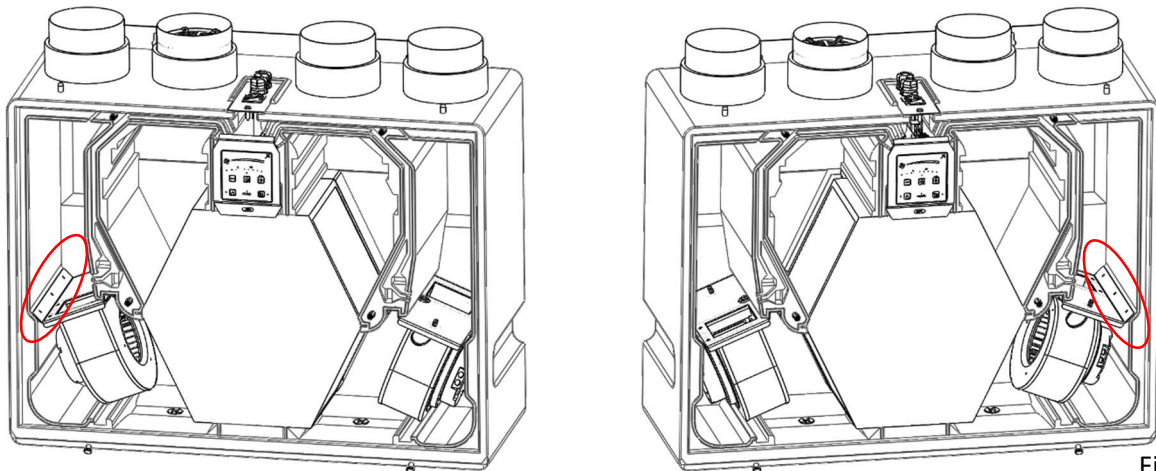

Fig. 56

- Carefully slide the fan beam and fan assembly (position 11) out of the slot in the unit body
- Vacuum dirt from the fan chamber and, if necessary, wipe it with a damp cloth with a common cleaning agent (e.g. soapy water).
- With extra care, vacuum dust from the fan assembly and, if necessary, wipe it with a damp cloth with a common cleaning agent (e.g. soapy water).

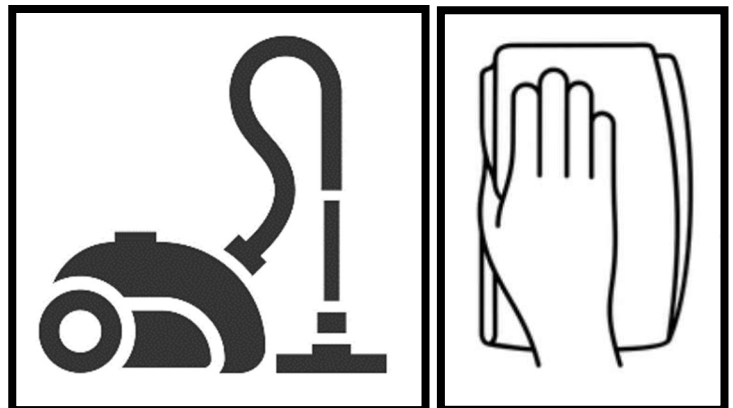
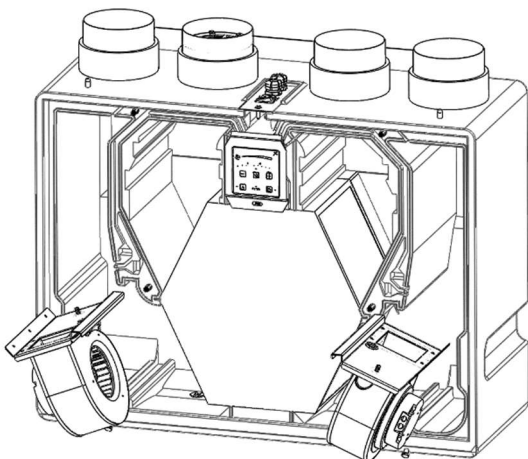

Fig. 57

7.2.2. Visual Inspection – Cleaning of the preheater, if fitted with the unit (XH2-030-ECxxxxP...)

- The preheater is accessible from the bottom of the filter location.
- In the event of dust contamination, clean the preheater by vacuuming with a vacuum cleaner.
- **Never remove the preheater or clean it with a damp cloth.**
- **Pay particular attention to the preheat supply cables to prevent damage to them - pulling them out of the junction box or out of the preheater**

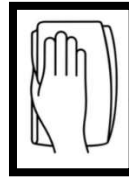
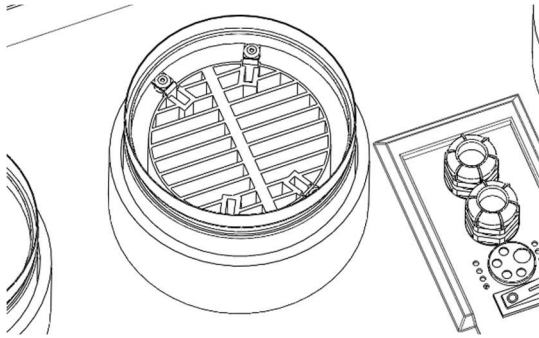
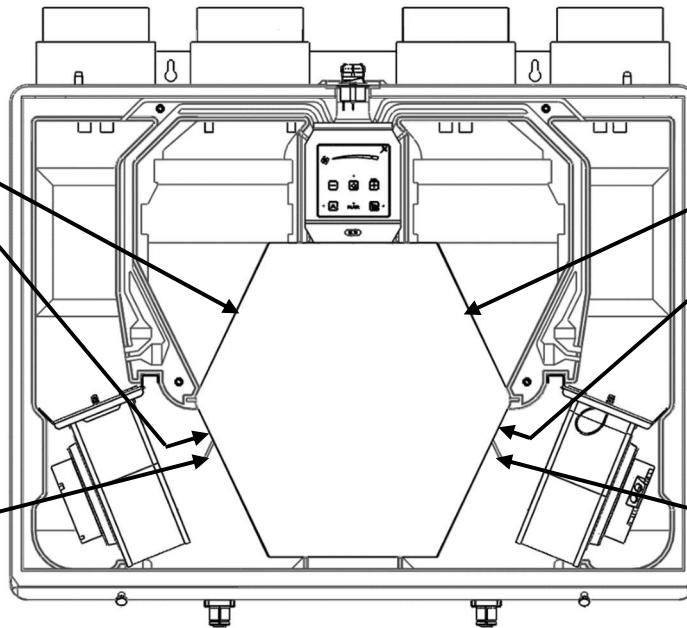



Fig. 58

7.2.3. Visual Inspection and Cleaning of the Heat Recovery Exchanger

- Then, visually inspect and clean the heat recovery exchanger (position 12)
- Vacuum the heat exchanger.
- **Beware of vacuuming around the heat recovery exchanger in the area of the air exhaust where the temperature sensor for anti-freeze protection is located in the heat exchanger.**



**ANTI-FREEZE
 SENSOR
 POSITION!!!
 RIGHT VERSION A**
 (e.g.: XH2-030-
 ECS0HRPAS-1A0)



**ANTI-FREEZE
 SENSOR
 POSITION!!!
 LEFT VERSION B**
 (e.g.: XH2-030-
 ECS0HRPBS-1A0)

Fig. 59

7.2.4. Re-installation of Internal Components into the Unit

- After inspection and cleaning, re-install the internal components into the unit.
- Slide the fan assembly into the grooves of the fitting. Pay attention to the correct storage of the fans.

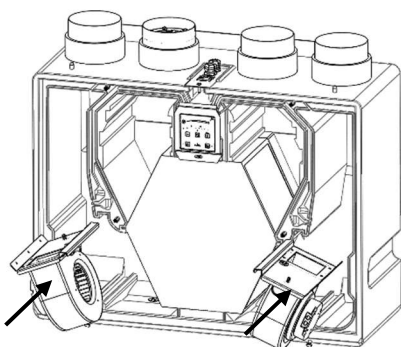

**TURN THE
 FANS BACK
 AND INSERT
 THEM
 CAREFULLY
 TO THEIR
 GROOVES**

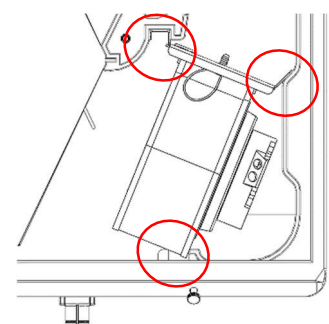
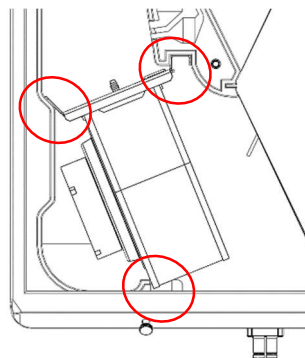

Fig. 60

- Secure the fan beams with 3 self-tapping screws.

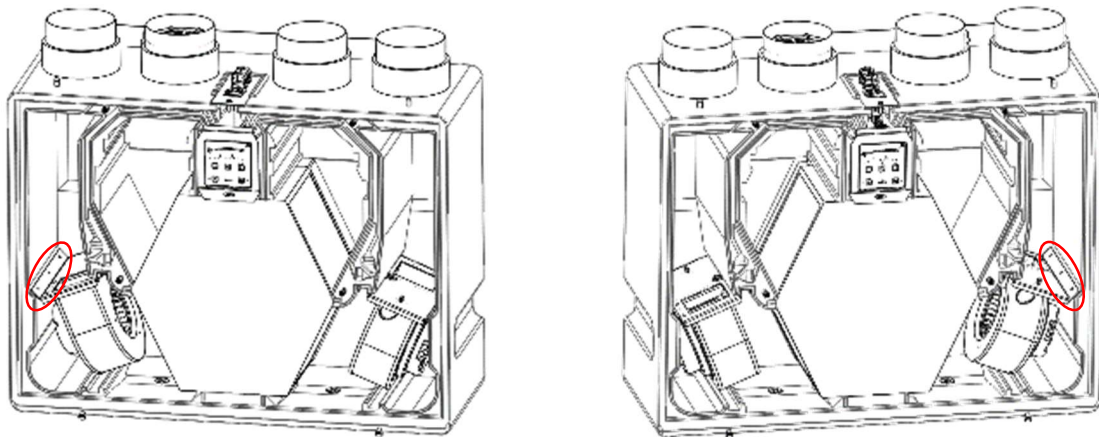

Fig. 61

- Align the fan cables so that they cannot be damaged.
- Fit the EPP unit lid (position 6) onto the bottom rail of the unit so that the bottom edge of the lid and the top edge of the unit rail are pressed together.
- Screw back the 5x M6x25 screw to secure the lid. Tighten it with adequate force to prevent them from turning.
- Secure the EPP cover of the unit through the control cover plate with a $\varnothing 3.5 \times 20$ self-tapping screw.

3) TIGHTEN THE 5x SCREW M6x25

4) SECURE THE CONTROLLER PLATE WITH A SELF-TAPPING SCREW

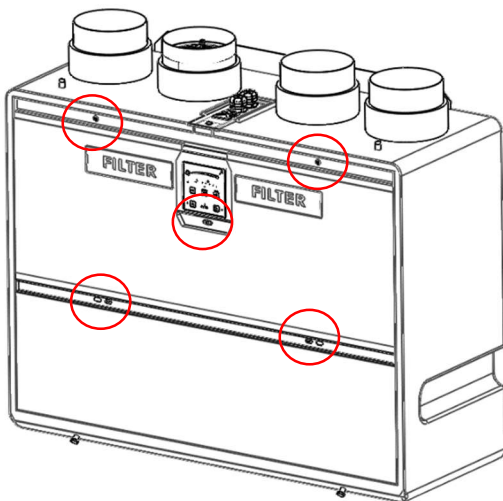

Fig. 62

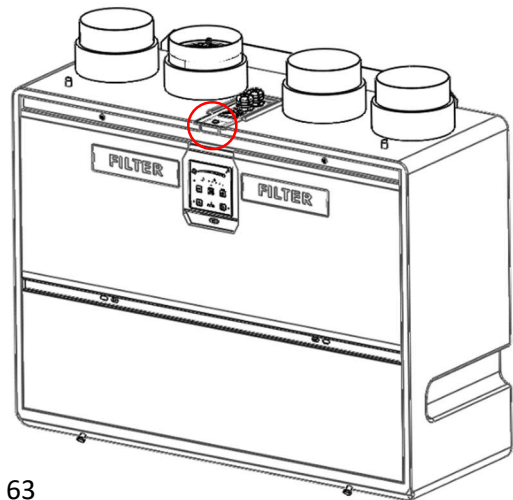

Fig. 63

5) INSERT THE FILTERS AND FILTER

6) PUT ON THE PLASTIC LID AND SECURE IT

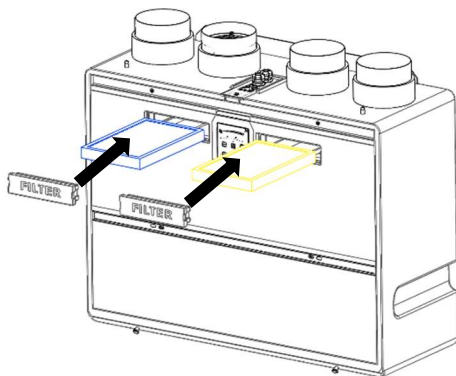

Fig. 64

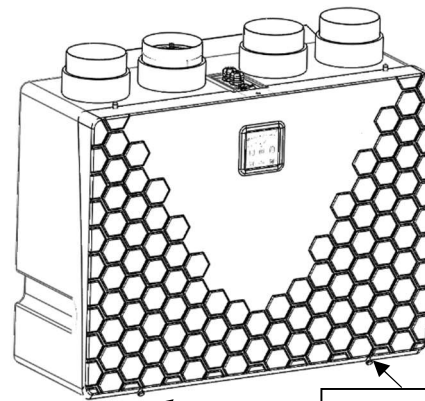

Fig. 65



- For the further procedure, refer to chapter 6.2. Filter Inserting
- To revive the unit after servicing, follow the steps in chapter 5.

8. Servicing



- Warranty and non-warranty servicing may only be performed by a qualified professionally trained worker and only using original spare parts.
- The manufacturer reserves the right to make changes to the device that do not affect the essential properties of the device.

8.1. Error Messages – Troubleshooting Procedure

Tab 24

Error No.	Error, fault message	Possible cause of failure	Troubleshooting	
1.	The unit does not start	The power cable is not connected	- check the mains connection - check the activation of the safety element	
		The main switch is in position 0	- set the switch to position I	
		The entire controller loading process did not take place	- Switch the unit off with the main switch and switch it on again, wait until the controller has finished loading - the controller stops flashing	
		Hold down button 2 (ON/OFF) for a short time, approx. 3 sec	- hold down button 2 (ON/OFF) until the LED above the button lights up	
2.	The unit does not start when first put into operation - LED above button 2 is lit	The demand for ventilation and heating is switched off	- Enter the unit setup regime and check the ventilation output request settings - Make the settings per chapter 5.4.2. table 14	
3.	Red indicator light above the FILTER sign is flashing	Filter clogging indication	- replace the filter according to Section 6.	
4.	No or low ventilation output even when the unit is set to the maximum power	Clogged filter	- replace the filter according to Section 6.	
		Contaminated - blocked piping, unit outlets	- Inspect the piping. Clean the unit per chapter 7.	
5.	Unit started to be too noisy	Clogged filter	- replace the filter according to Section 6.	
		Fan distribution wrongly set	- Check and re-set the fan distribution per chapter 5.5.4.	
		Defective motor bearing	- contact the unit supplier	
6.	Electrical heating of the unit does not heat	Clogged filter - no flow	- replace the filter according to Section 6.	
		Contaminated - blocked piping, unit outlets	- Check and clean the unit according to Section 7.	
		activated heat exchanger protection against overheating	- switch off the unit with the main switch. Turn the unit on again after 5 minutes (reset of protection). If the problem persists, contact the unit supplier	
7.	Unable to activate the night cooling function - bypass (button 6) - The button signalling flashes 3 times and the function does not switch on	Function start requirements are not met - outside temperature too low	- Wait for the outside temperature to rise. The function is active only at summer temperatures.	
8.	The night cooling function cannot be switched on (button 6.) - all the status diodes flash once (at buttons 6, 4, 7, 10), the function does not switch on	BOOST function active	- Wait for the BOOST regime to end - Switch off the BOOST function per chapter 4.2.4.	
		Active child lock function	- Switch off the child lock function per chapter 5.4.2. Tab. 14	
9.	The BOOST mode cannot be switched on - status diodes flash once or 3 times (at buttons 6, 4, 7, 10), the function does not switch on	3 flashes - very low outdoor temperature	- wait for the outdoor temperature to rise	
		1 flash - child lock function is active	- Switch off the child lock function per chapter 5.4.2. Tab. 14	
10.	The automatic mode cannot be started when the button 4 is pressed, the indicator flashes 3 times or lights	3 flashes - unit is not fitted with any AQS sensor	- You have no AQS sensor connected. - Check the AQS sensor wiring	
11.	When any button is pressed, the status diodes flash once (at buttons 6, 4, 7, 10)	Active child lock function	- Switch off the child lock function per chapter 5.4.2. Tab. 14	
12.	The unit is inoperable and the 4 LEDs on the range for adjusting the ventilation power on the control panel are continuously flashing	- diodes 1; 2; 3; 4 are flashing	Supply fan failure	
13.		- diodes 5; 6; 7; 8 are flashing		Exhaust fan failure
14.		- diodes 3; 4; 5; 5 are flashing		Faulty anti-freeze sensor

8.2. Failure persists

- Restart the unit – switch off the unit on the controller (button 2), switch off the unit using the main switch (position 16). Wait approx. 30 s and restart the unit.
- In the event of a persistent failure of the unit, do not attempt to repair the unit yourself.
- Switch the unit off using the main switch and disconnect it from the mains.
- Secure the unit against restarting or handling by an unauthorised person.
- Contact your seller.

9. Final Decommissioning, Dismantling, and Disposal

- At the end of the machine's service life or when it would be uneconomical to repair it, dismantle the machine completely.
- During the dismantling process, the generally applicable safety regulations must be observed for the safe execution of all the work activities.
- Once the machine is completely dismantled, dispose of the individual parts in accordance with the requirements of the Waste Act No. 541/2020 Coll., as amended.
- Separate the metal components by the type of metal and hand them over to the relevant organisations dealing with the reusable waste collection.
- The parts made of plastic materials and rubber that are not subject to natural decomposition shall be sorted out and sold to an organisation dealing with collection of such reusable waste materials.
- Parts of electrical equipment are handed over to the organisation responsible for electrical waste collection.

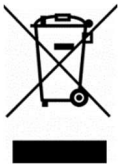

Please, return all unwanted or obsolete products and packaging to the relevant recycling sites where they will be disposed of professionally. Dispose of the parts of the product that cannot be utilised to a controlled landfill. Only a product recycled in this way can be reused properly and returned to the utility.



10. Warranty

The warranty per unit is valid according to legal regulations. The warranty only applies if all the installation and maintenance instructions have been followed. The warranty covers manufacturing defects, material defects, or device operation defects. We do not guarantee the suitability of using the unit for special purposes, determination of suitability is fully within the customer's competence.

The warranty does not cover defects caused by:

- improper handling,
- during transport (damage caused by transport – financial compensation must be resolved with the carrier),
- failing to comply with the service conditions,
- incorrect electrical connection or protection,
- incorrect operation,
- product intervention,
- regular wear and tear,
- due to a natural disaster.

If the warranty is claimed, it is necessary to submit a report (provided in the product documentation) containing:

- complainant/company information,
- date and number of the sales document,
- detailed description of the defect,
- data on socket protection,
- photo of the product's manufacturing label and, where appropriate, a serial number,

- photo from the product's installation site,
- measured product values: air temperature, voltage, current.

In the case of both warranty and post-warranty service, contact your supplier or installation company that performed your installation. The method of handling a warranty repair is carried out at the unit installation site or as agreed. The method of resolving warranty repairs is exclusively at the discretion of the company's service centre. The complaining party shall receive a written statement on the result of the complaint – warranty repair. In the case of an unjustified complaint, all the costs relating to such complaint shall be borne by the complainant.

11. In Conclusion

If you have any questions about this product, do not hesitate to contact us.

Contact Address:

Xvent s.r.o.
Poděbradská 289
53009 Pardubice-Trnová
Czech Republic
www.xvent.cz

